



Tiptap
Skateparks





Tiptiptap skateparks

With over 15 years of experience Tiptiptap offers today more than 200 different solutions. Our skateparks have been developed in partnership with professional riders who know how to challenge their BMX, skateboards, scooters, inliners and more.

Using a skatepark is a great fun but it must be safe. We never compromise on that. Therefore, all our skatepark elements have been manufactured in accordance with the European safety standard EN 14974 and certified by TÜV SÜD GmbH.

The product choice includes both steel and wooden frame elements, either with phenol coated waterproof plywood or professional composite surface- all high quality and weather resistant. Our skateparks evolve in line with the requests and needs of our clients and we try to fulfill the wishes of even the most demanding customers.

Base + and Steel PRO professional riding surface is a super-durable, weather-resistant composite material that is designed to withstand the high pressures and various impacts occurring at public skateparks. It comes with a tracking resistant surface and good mechanical properties as well as adequate arc resistance.

Base / Base+

- ① Hot galvanized steel safety railing.
- ② Top layer:
BASE Waterproof plywood with antislip phenole film
BASE + Professional riding surface
- ③ Bottom layer: Laminated (FF) waterproof plywood
- ④ Dried, planed and impregnated timber beams. All the beams are mounted in special deepening in plywood.
- ⑤ Hot galvanized steel sheet.
- ⑥ Frame made from thick laminated (FF) waterproof plywood.
- ⑦ Decorative side and back cover made from high quality laminated (FF) waterproof plywood.
- ⑧ Hot galvanized steel tube
- ⑨ Unique joint system for smooth connection of riding surface and steel sheet with asphalt or concrete.
- ⑩ All frame details are connected to each other by a puzzle-type connection to give additional stability and strenght

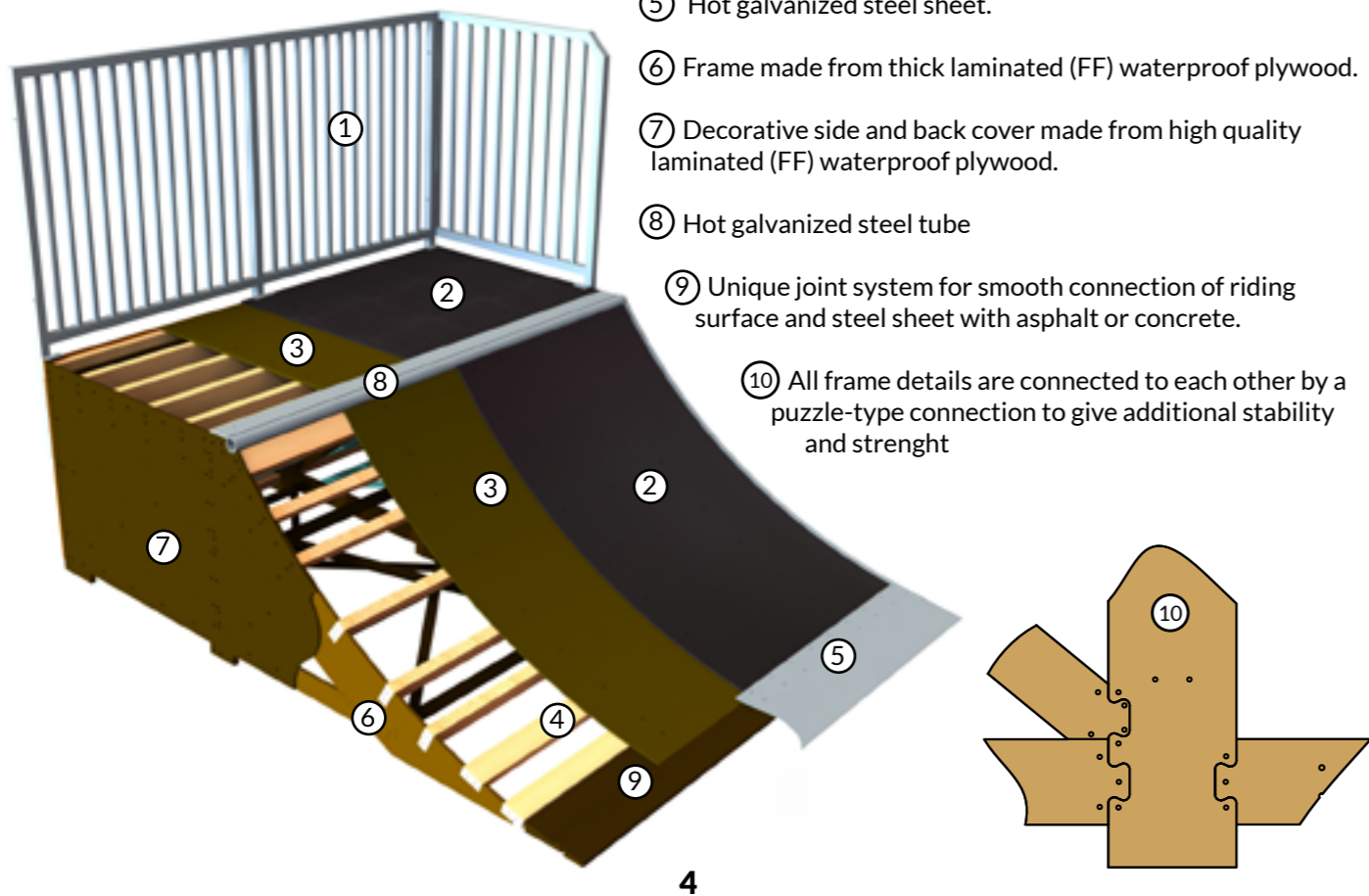

4

Steel / Steel PRO

(Steel PRO is maintenance free)

- ① Hot galvanized steel safety railing.
- ② Top layer:
STEEL Waterproof plywood with antislip phenole film
STEEL PRO Professional riding surface
- ③ Bottom layer and side and back panels:
STEEL Laminated (FF) waterproof plywood
STEEL+ HDPE
- ④ Frame is made from hot galvanized steel.
- ⑤ Hot galvanized steel sheet.



5



Dots under the icons indicate the usability of a skatepark for each type of riders:

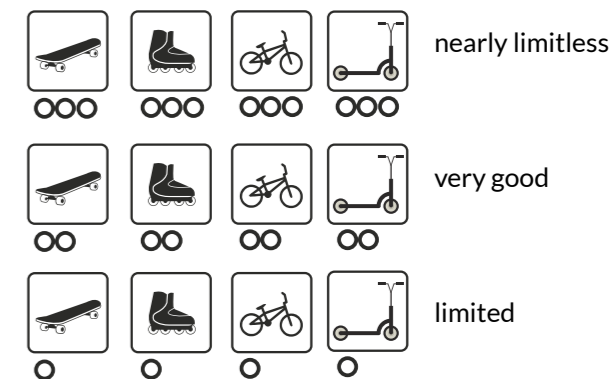

Ready-made solutions

To make clients' choice easier our experienced skatepark development team has developed over 40 ready-made skatepark solutions. These are suitable for skateboarders and skaters as well as riders with BMX bikes and scooters.

This can be described as a classic skatepark. Advantage of this type of skatepark solutions is that they have been already designed for skatepark users and you only have to choose the one that suits your park requirements and budget. Our ready-made solutions can be placed on any flat surface, such as concrete or asphalt.

Tiptaptap ready-made skatepark solutions are available in 4 different material combinations: BASE, BASE +, STEEL and STEEL PRO.



B100



Park area: 165m²
 Riding surface: 33m²
 Dimensions: 22x7,5x1m

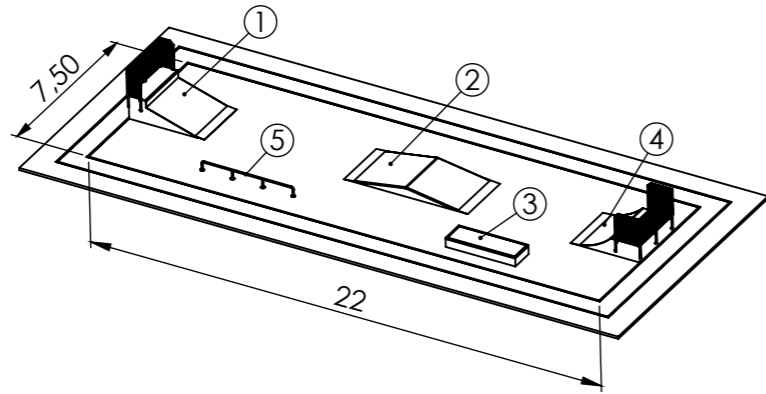

	Obstacle name	Height m	Width m	Length m	Height with barrier m
1	Bank with subbox	1,0	2,44	3,7	2,2
2	Funbox	0,4	2,4	5,3	
3	Grind box	0,4	1,0	3,0	
4	Quarterpipe	0,7	2,4	3,0	1,9
5	Grind rail	0,4	0,06	4,0	

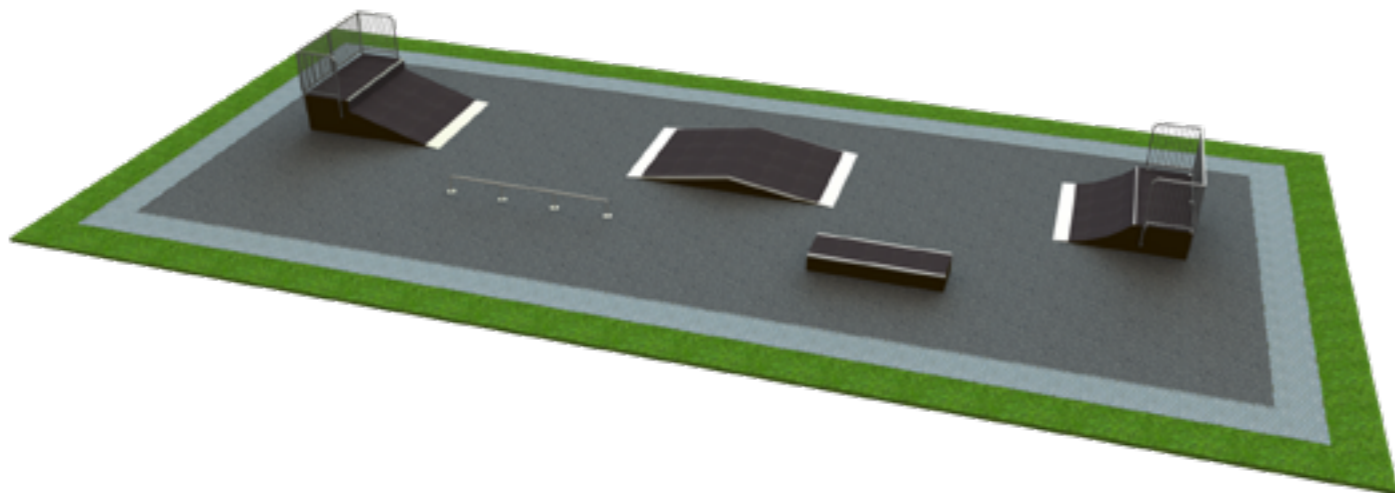

10

B103



Park area: 270m²
 Riding surface: 33m²
 Dimensions: 30x9x1,2m

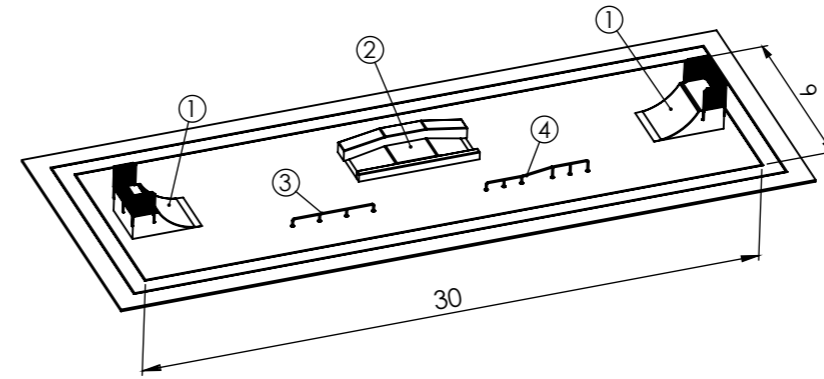

	Obstacle name	Height m	Width m	Length m	Height with barrier m
1	Quarterpipe	1,2	2,44	3,4	2,4
2	Funbox	0,9	2,55	6,0	
3	Grind rail	0,4	0,06	4,0	
4	Grind rail	0,4/0,6	0,06	5,0	

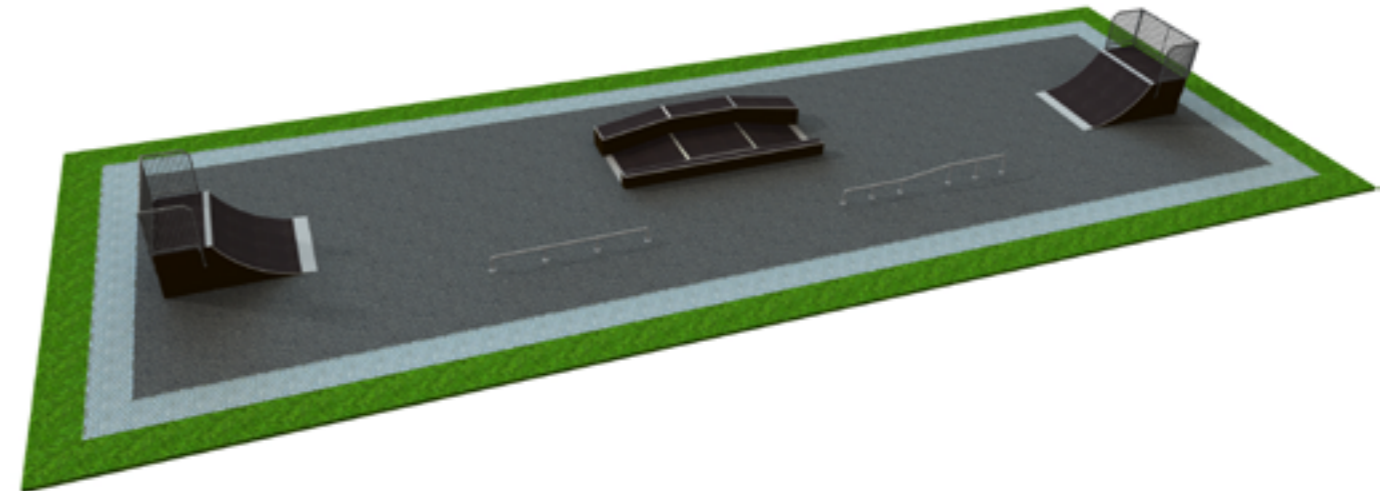

11

B105



Park area: 225m²
 Riding surface: 40m²
 Dimensions: 25x9x1m

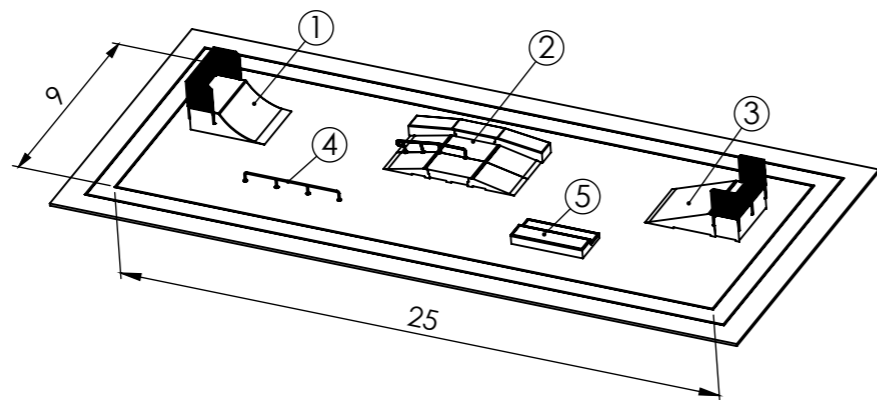

	Obstacle name	Height m	Width m	Length m	Height with barrier m
1	Quarterpipe	1,0	2,44	3,1	2,2
2	Funbox	0,7	3,2	5,6	
3	Bank	1,0	2,44	4,0	2,2
4	Grind rail	0,4	0,06	4,0	
5	Grind box	0,4/0,2	1,5	3,0	

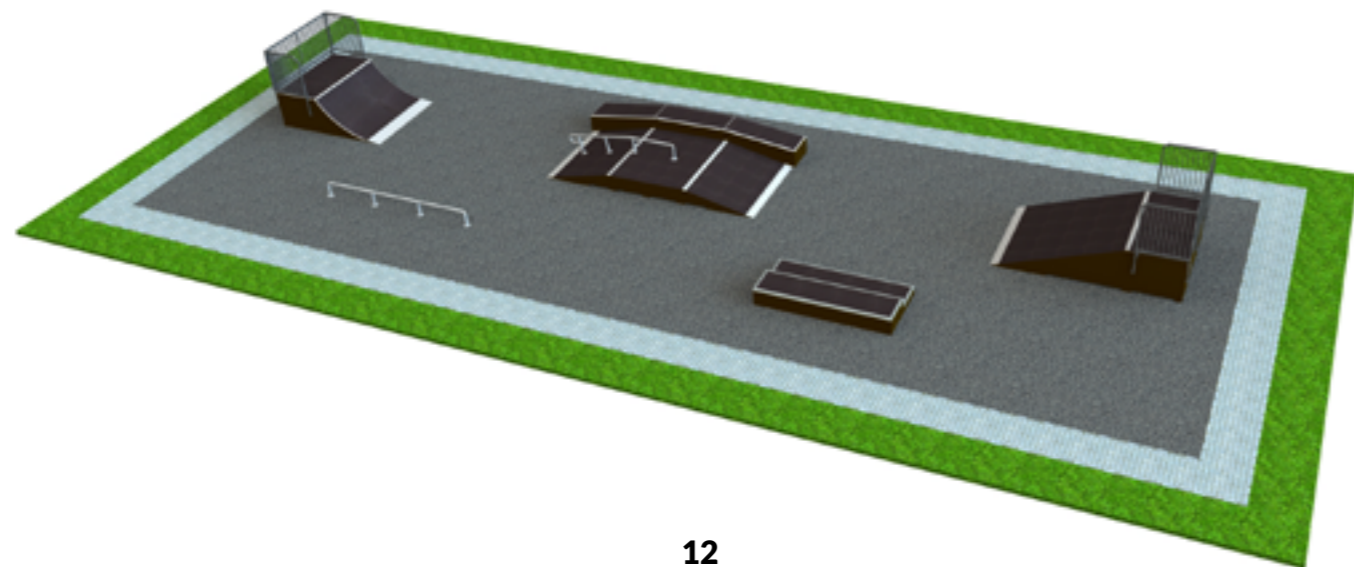

12

B108



Park area: 280m²
 Riding surface: 44m²
 Dimensions: 28x10x1,2m

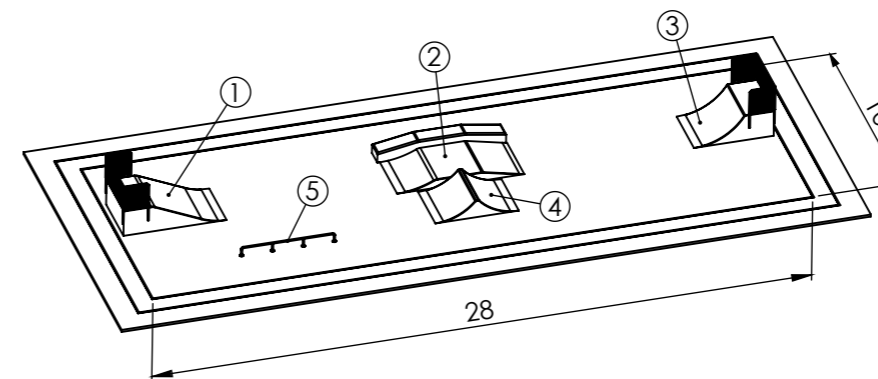

	Obstacle name	Height m	Width m	Length m	Height with barrier m
1	Bank	1,2	2,44	4,4	2,4
2	Funbox set	0,75	3,25	5,4	
3	Quarterpipe	1,2	2,44	3,4	2,4
4	Spine	0,8	2,44	3,5	
5	Grind rail	0,4	0,06	4,0	

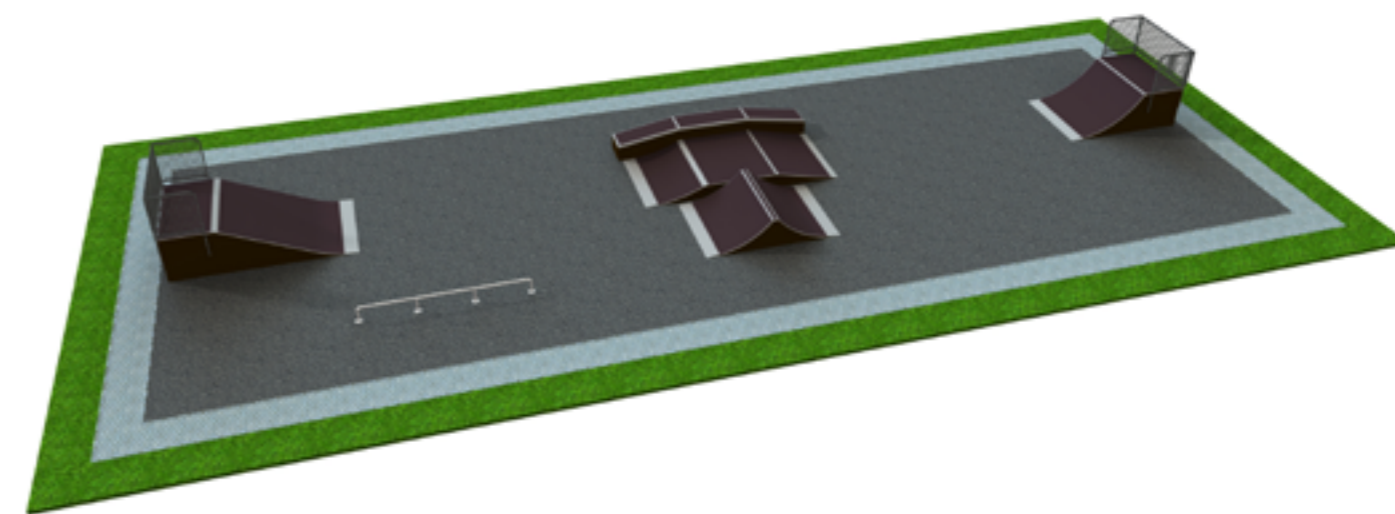

13

B110



Park area: 150m²
 Riding surface: 64m²
 Dimensions: 25x6x1,5m

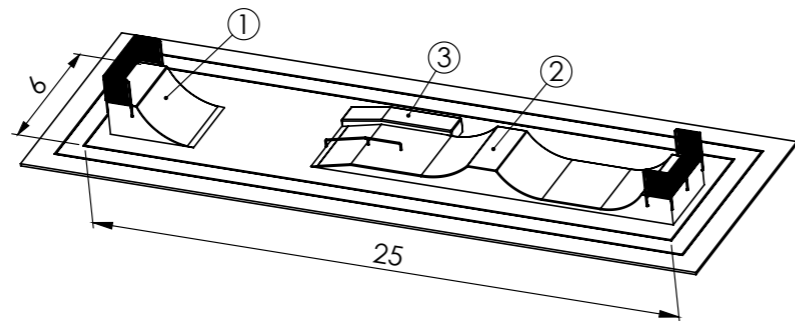

	Obstacle name	Height m	Width m	Length m	Height with barrier m
1	Quarterpipe	1,5	3,0	3,5	2,7
2	Double set	1,2	3,0	15,5	2,4
3	Grind box	0,6	1,0	4,7	

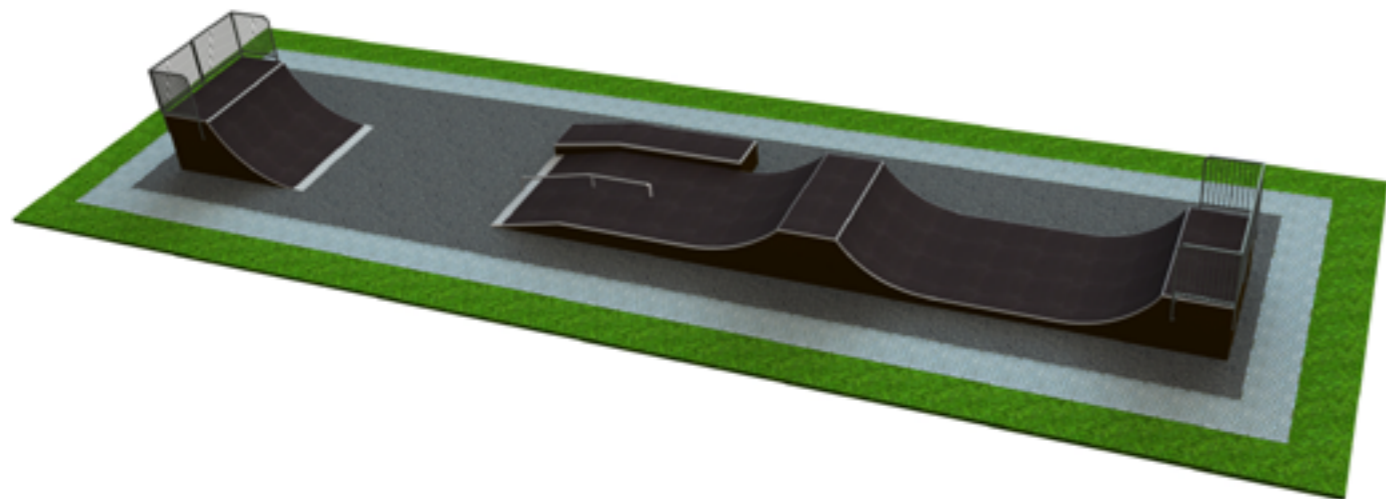

14

B111



Park area: 450m²
 Riding surface: 69m²
 Dimensions: 30x15x1,5m

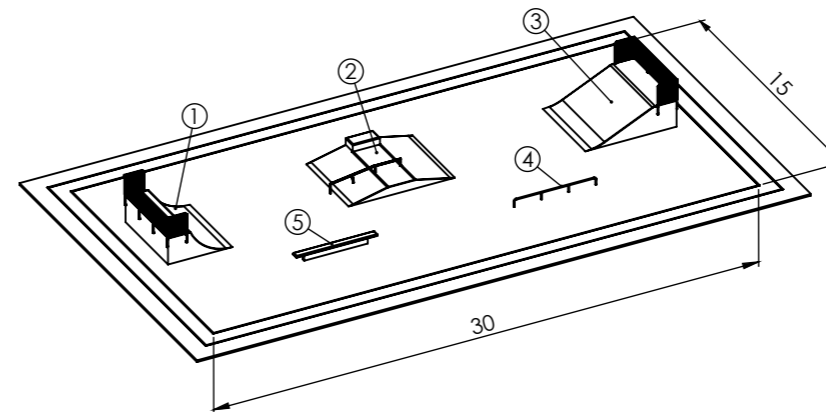

	Obstacle name	Height m	Width m	Length m	Height with barrier m
1	Quarterpipe	1,5	4,5	3,5	2,7
2	Funbox	0,9/0,5	4,5	5,8	
3	Bank	1,5	4,5	5,0	2,7
4	Grind rail	0,4	0,06	4,0	
5	Grind box	0,45	0,4	4,5	

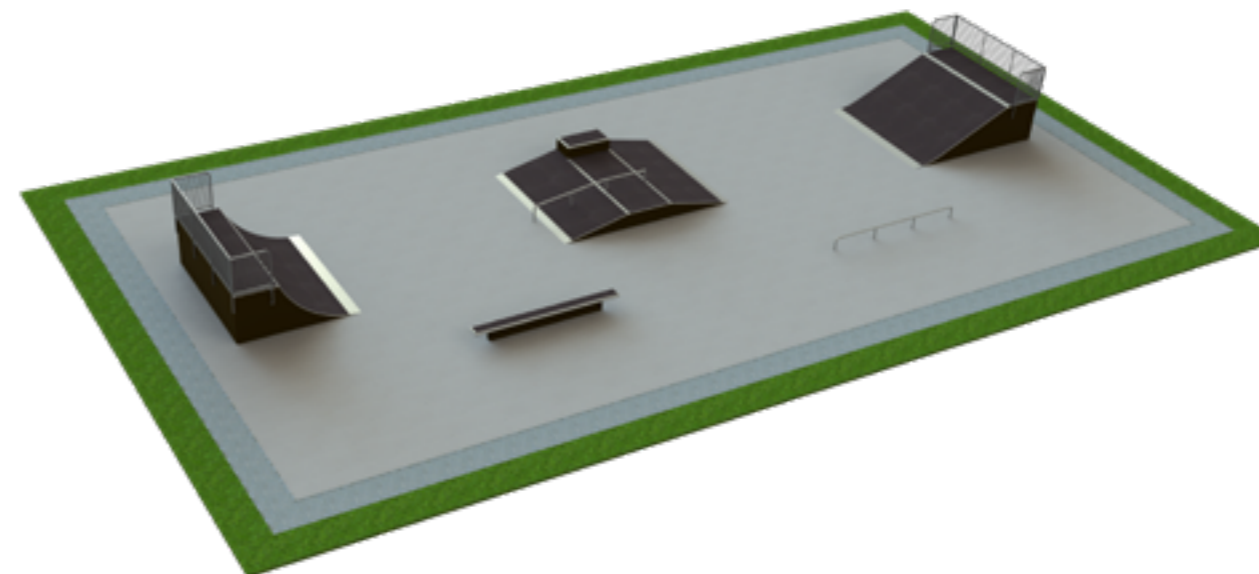

15

B112



Park area: 600m²
Riding surface: 80m²
Dimensions: 30x20x1,5m

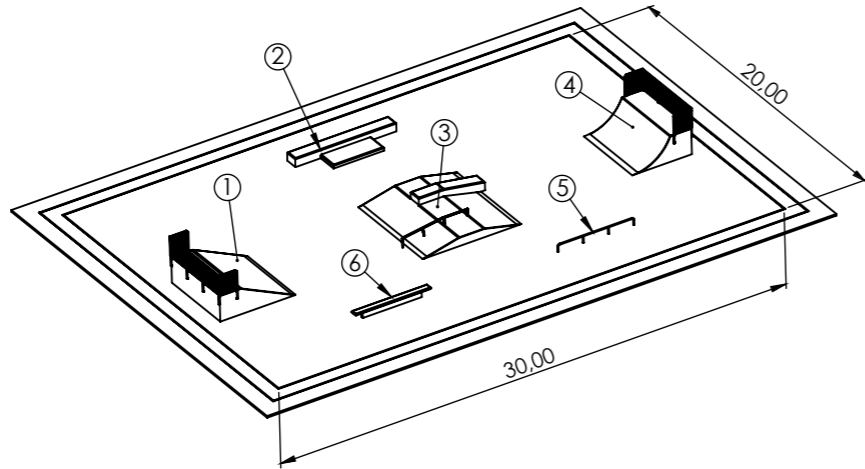

	Obstacle name	Height m	Width m	Length m	Height with barrier m
1	Flat bank	1,5	4,5	4,5	2,7
2	Grind box	0,5/0,2	1,95	6,0	
3	Funbox	0,9/0,5	6,0	6,1	
4	Quarterpipe	1,5	4,5	3,6	2,7
5	Grind rail	0,4	0,06	4,0	
6	Grind box	0,45	0,4	4,5	

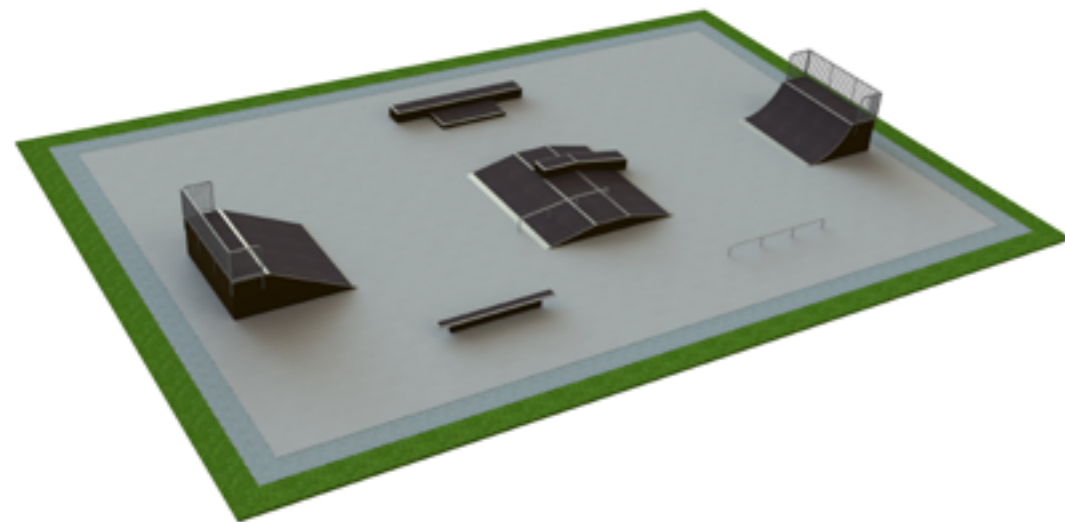

16

B115



Park area: 450m²
Riding surface: 106m²
Dimensions: 30x15x1,5m

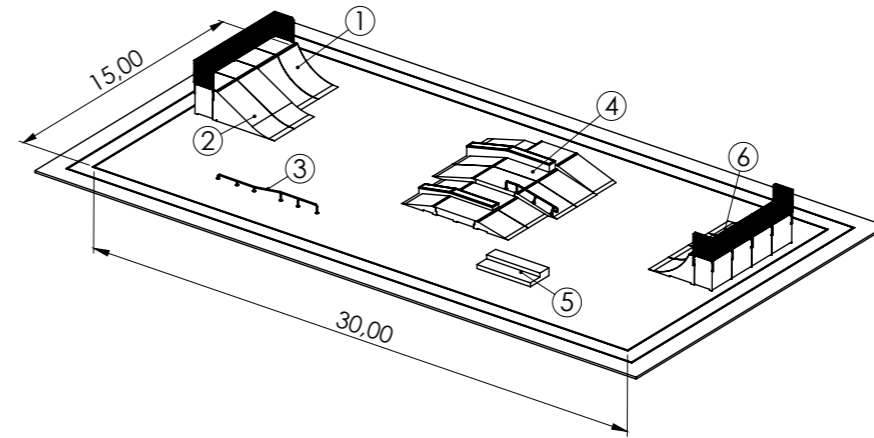

	Obstacle name	Height m	Width m	Length m	Height with barrier m
1	Quarterpipe	1,5	3,0	3,6	2,7
2	Bank	1,5	3,0	4,5	2,7
3	Grind rail	0,4/0,6	0,06	5,0	
4	Funbox	1,0	7,5	7,2	
5	Grind box	0,4/0,2	1,5	3,0	
6	Quarterpipe	1,5	6,0	3,6	2,7

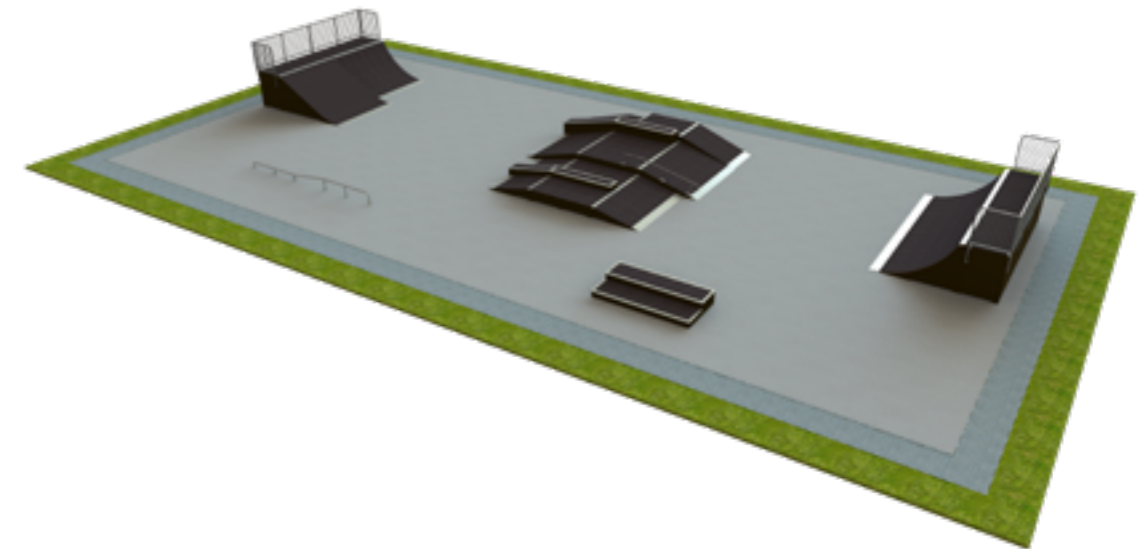

17

B120



Park area: 375m²
Riding surface: 121m²
Dimensions: 25x15x1,5m

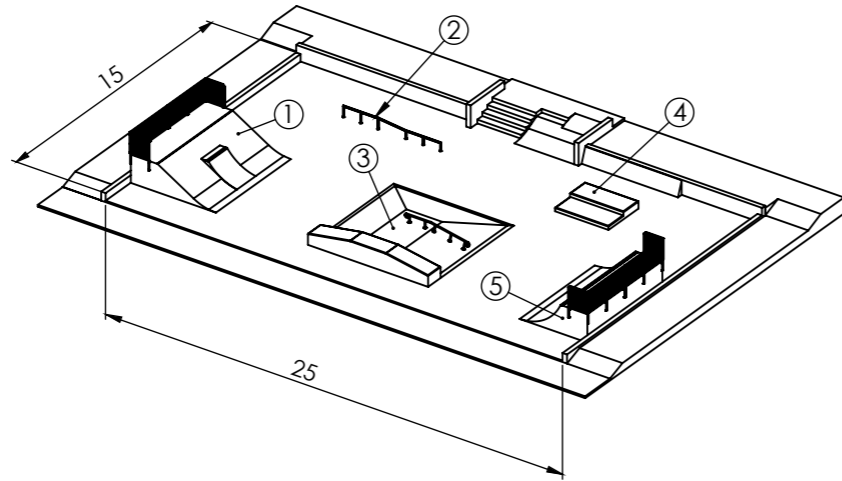

	Obstacle name	Height m	Width m	Length m	Height with barrier m
1	Bank	1,5	6,0	4,7	2,7
2	Grind rail	0,4/0,6	0,06	5,0	
3	Funbox	1,0/0,5	6,7	6,8	
4	Grind box	0,2/0,4	2,4	3,0	
5	Quarterpipe	1,5	6,0	3,8	2,7

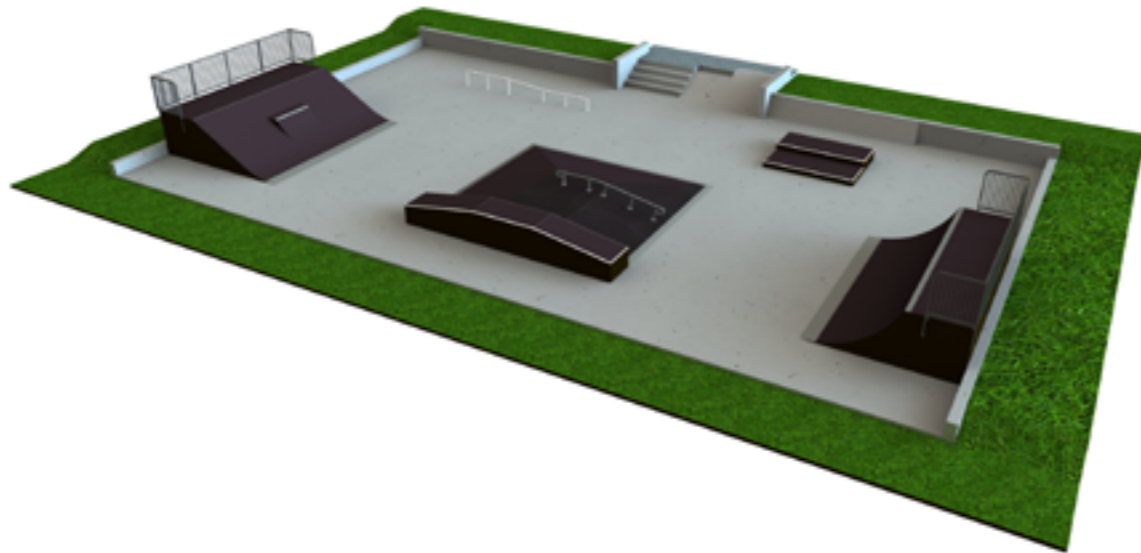

18

B125



Park area: 336m²
Riding surface: 125m²
Dimensions: 28x12x2m

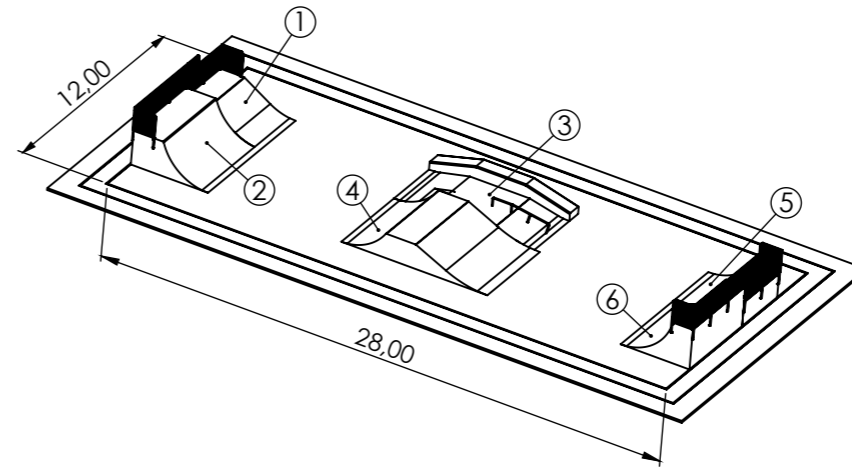

	Obstacle name	Height m	Width m	Length m	Height with barrier m
1	Bank	1,2	3,0	3,8	2,4
2	Quarterpipe	1,7	4,5	3,8	2,9
3	Funbox	1,0/0,4	3,75	7,0	
4	Flybox	1,2	4,5	7,3	
5	Quarterpipe	1,2	3,0	3,5	2,4
6	Quarterpipe	2,0	4,5	3,5	3,2

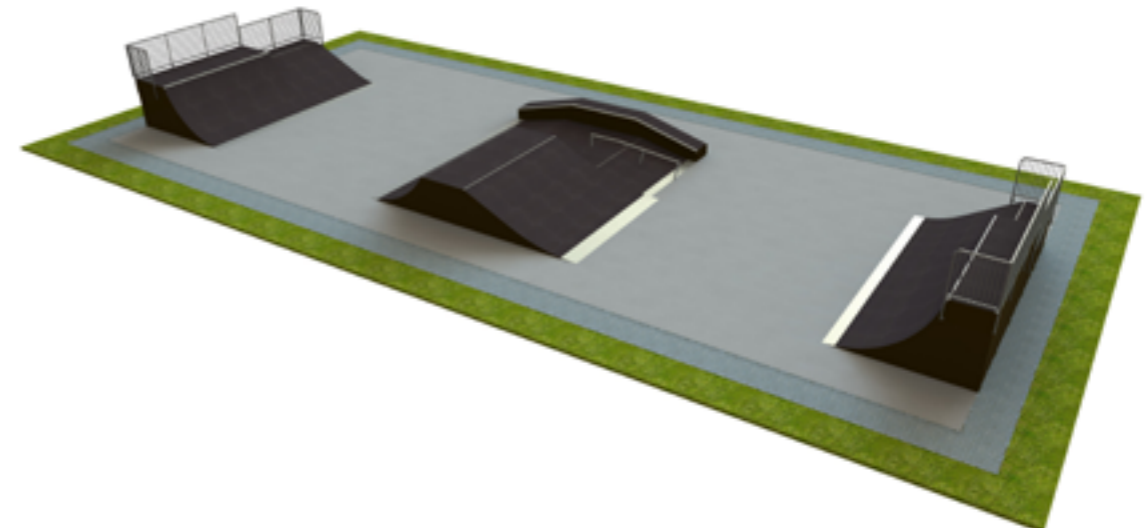

19

B130



Park area: 338m²
Riding surface: 145m²
Dimensions: 26x13x2m

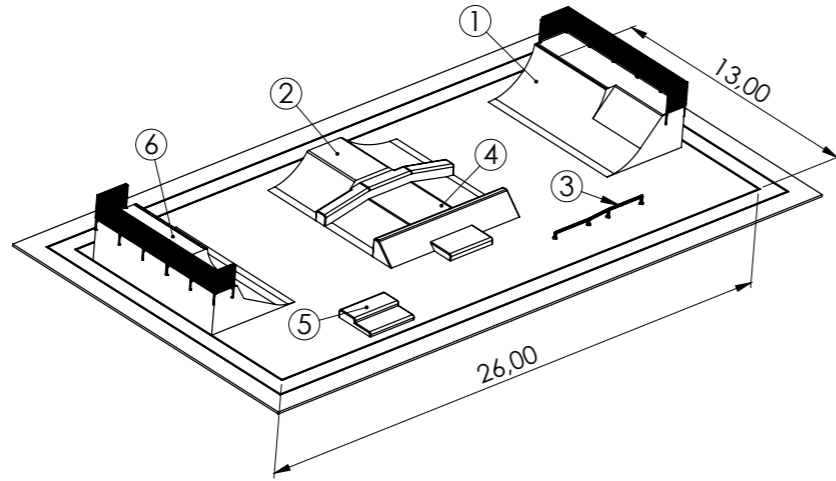

	Obstacle name	Height m	Width m	Length m	Height with barrier m
1	Quarterpipe with bank	2,0	7,5	4,2	3,2
2	Flybox	1,2	3,0	7,3	
3	Grind rail	0,4/0,6	0,06	5,0	
4	Funbox	0,9/0,5	5,8	7,3	
5	Grind box	0,4/0,2	2,0	2,5	
6	Quarterpipe with drop	2,0	7,5	4,7	3,2

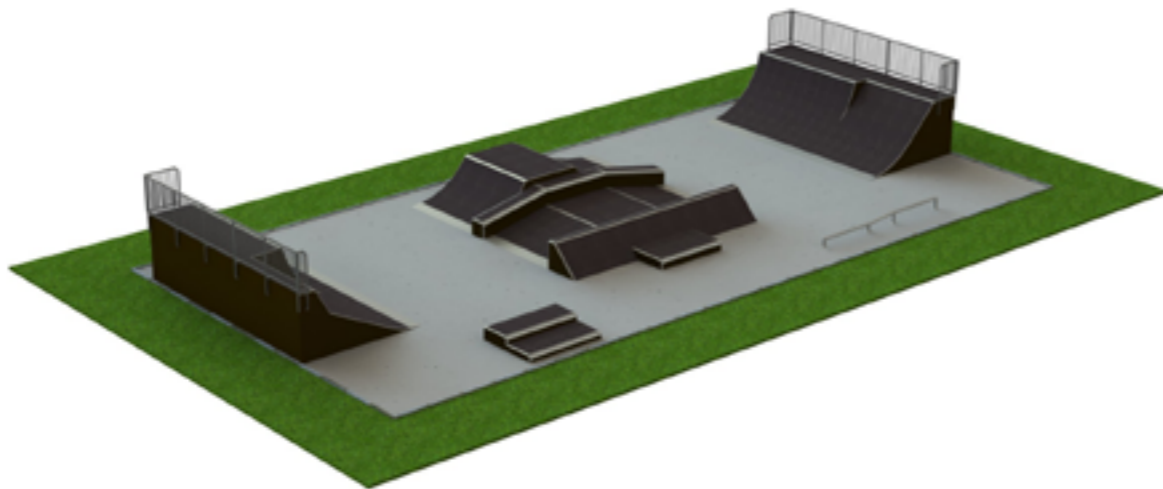

20

B132



Park area: 300m²
Riding surface: 150m²
Dimensions: 22,5x19,2x1,5m

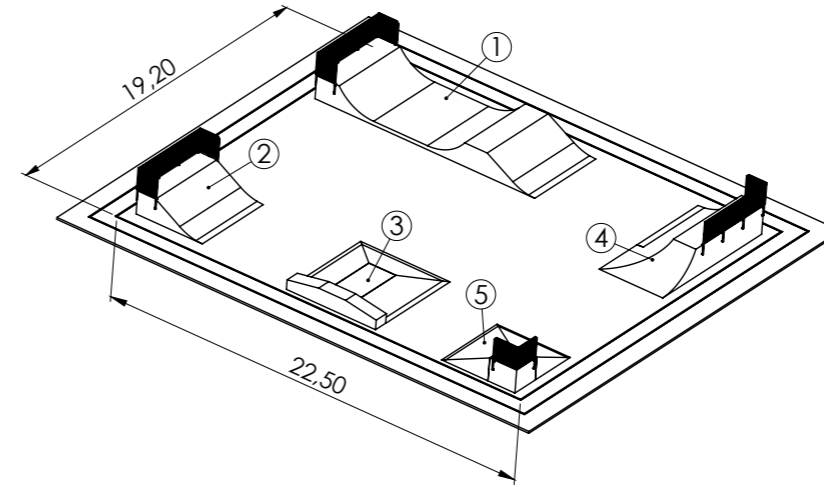

	Obstacle name	Height m	Width m	Length m	Height with barrier m
1	Halfpipe set	1,2	4,5	12,3	2,4
2	Bank	1,2	4,5	3,7	2,4
3	Funbox	0,8/0,4	5,5	5,0	
4	Quarterpipe corner	1,5	7,3	3,6	2,7
5	Pyramid corner	1,2	4,1	4,1	2,4

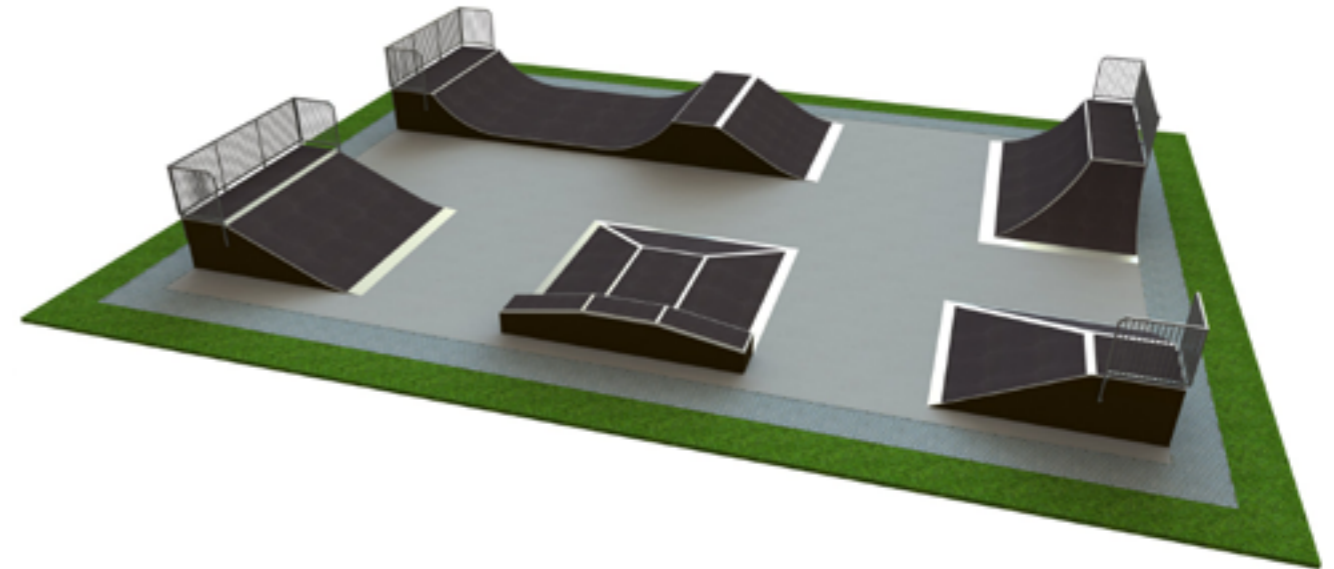

21

B134



Park area: 875m²
Riding surface: 154m²
Dimensions: 35x25x3,5m

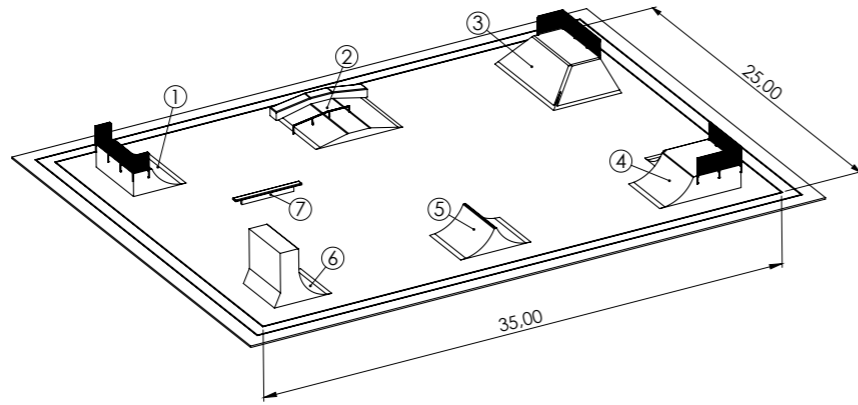

	Obstacle name	Height m	Width m	Length m	Height with barrier m
1	Quarterpipe	1,5	4,5	3,6	2,7
2	Funbox	0,9/0,5	5,25	6,2	
3	Corner	1,2	7,1	4,6	2,4
4	Quarterpipe corner	1,5	5,5	6,3	2,7
5	Spine	1,5	3,75	4,7	
6	Wallride	3,5	3,75	3,8	
7	Grind box	0,45	0,4	4,5	

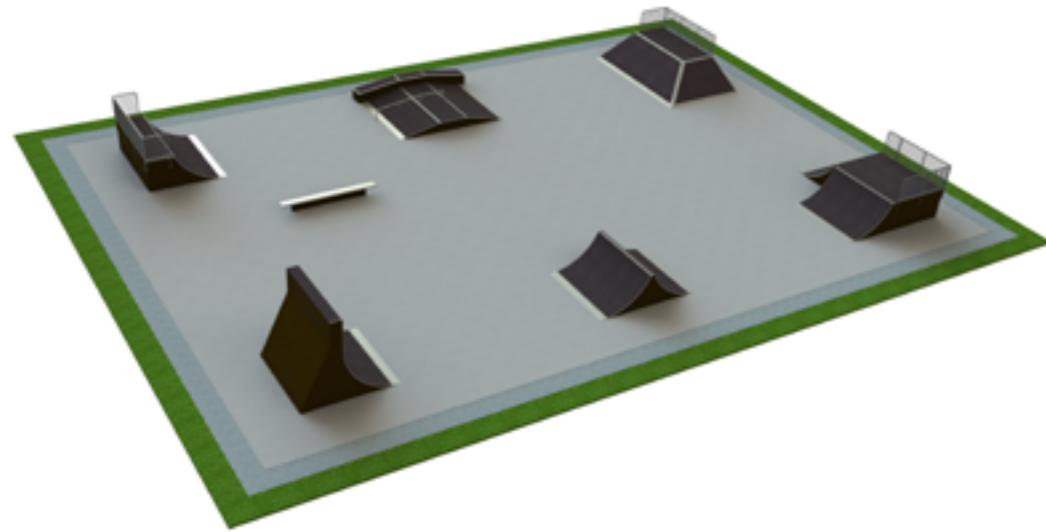

22

B135



Park area: 440m²
Riding surface: 153m²
Dimensions: 29x29x1,5m

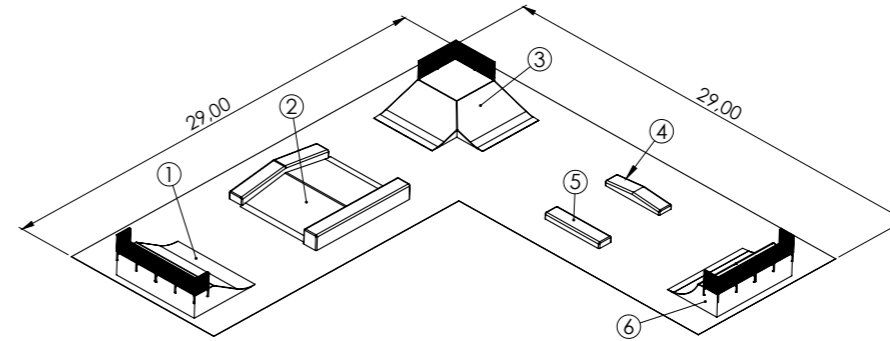

	Obstacle name	Height m	Width m	Length m	Height with barrier m
1	Bank	1,5	6,0	4,9	2,7
2	Funbox	1,0/0,6	7,0	7,5	
3	Corner	1,0	6,5	6,5	2,2
4	Grind box	0,5	1,0	4,2	
5	Grind box	0,4	1,0	4,2	
6	Quarterpipe	1,5	6,0	3,8	2,7

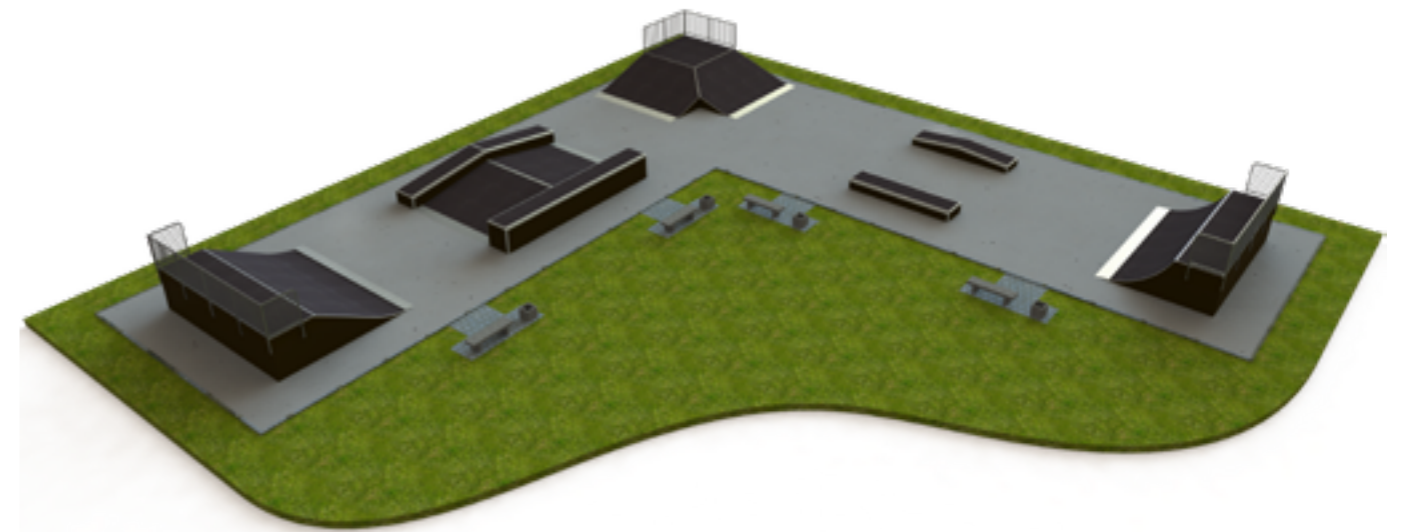

23

B140



Park area: 260m²
Riding surface: 150m²
Dimensions: 25x13x1,2m

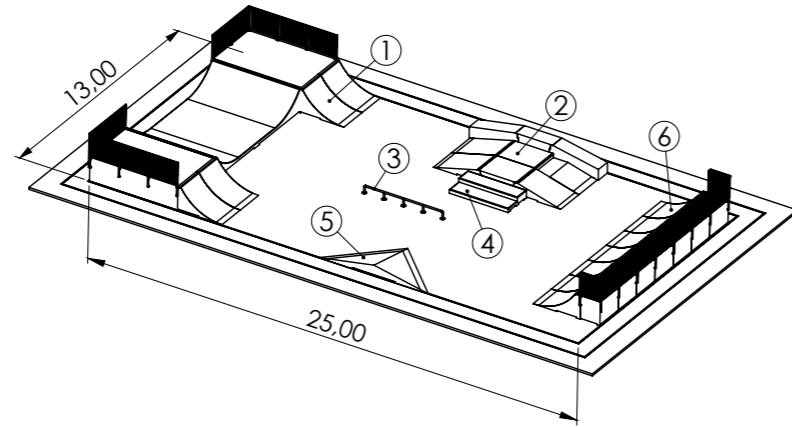

	Obstacle name	Height m	Width m	Length m	Height with barrier m
1	Halfpipe combo	1,2	6,8	13	2,4
2	Funbox	1,0/0,6	3,75	6,6	
3	Grind rail	0,4	0,06	4,0	
4	Grind box	0,2/0,4	1,5	3,0	
5	Pyramid corner	0,5	5,6	2,8	
6	Quarterpipe	1,2	10,5	3,4	2,4

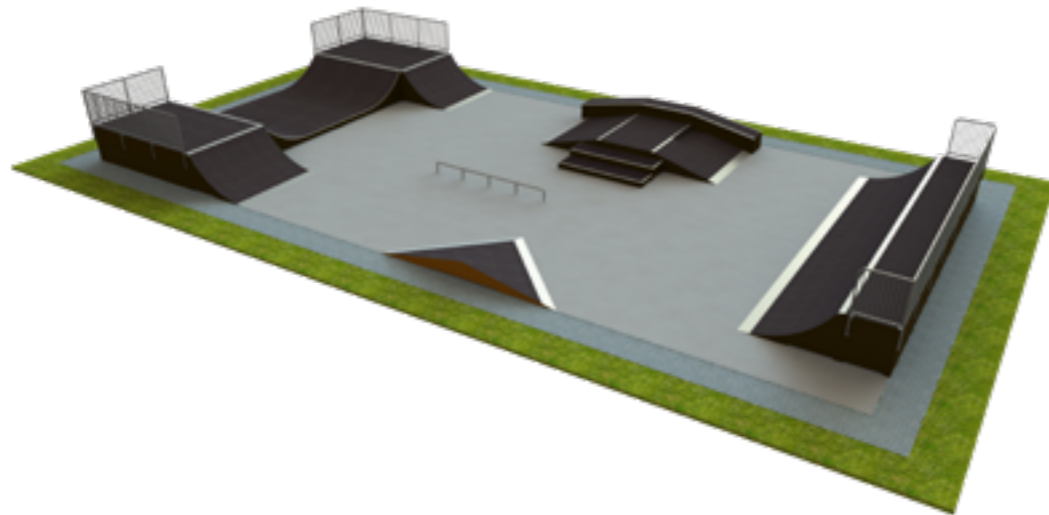

24

B141



Park area: 1000m²
Riding surface: 154m²
Dimensions: 40x25x1,5m

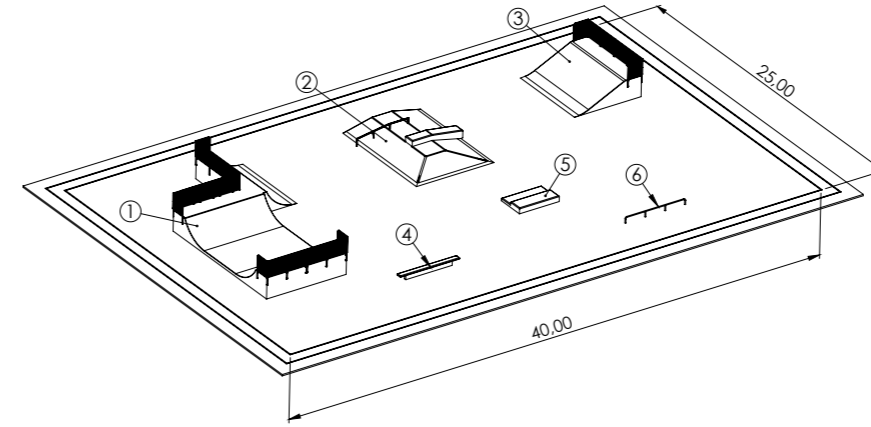

	Obstacle name	Height m	Width m	Length m	Height with barrier m
1	Miniramp with quarterpipe	1,5	8,5	15,2	2,7
2	Funbox	0,5/0,9	8,1	6,0	
3	Bank	1,5	6,0	5,0	
4	Grind box	0,45	0,4	4,5	
5	Grind box	0,2/0,4	2,0	3,0	
6	Grind rail	0,4	0,06	4,0	

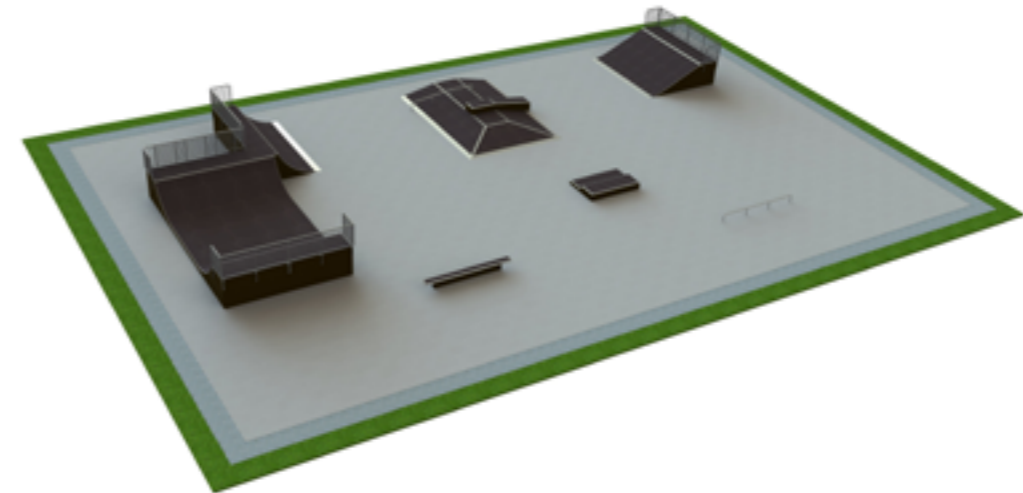

25

B143



Park area: 1200m²
 Riding surface: 170m²
 Dimensions: 40x30x1,5m

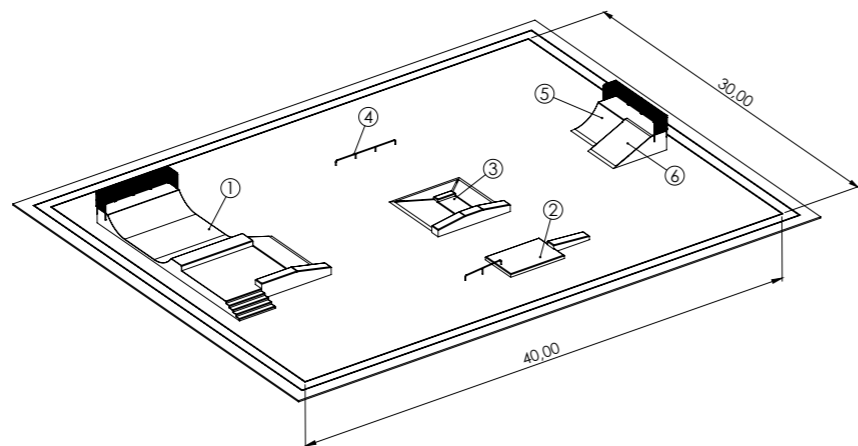

- 1
- 2
- 3
- 4
- 5
- 6

Obstacle name	Height m	Width m	Length m	Height with barrier m
1 Halfpipe with funbox	1,2	8,8	16,85	2,4
2 Grind box	0,25/0,55	3,0	10,2	
3 Funbox	0,5/0,9	6,0	6,0	
4 Grind rail	0,4	0,06	5,0	
5 Quarterpipe	1,5	3,0	3,8	2,7
6 Flat bank	1,5	3,0	4,5	2,7

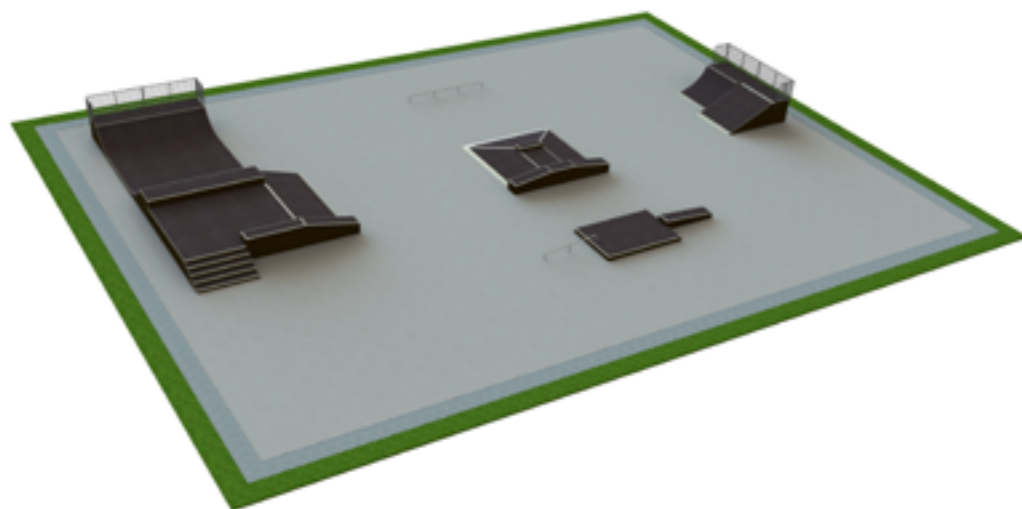

B144



Park area: 750m²
 Riding surface: 155m²
 Dimensions: 30x25x1,5m

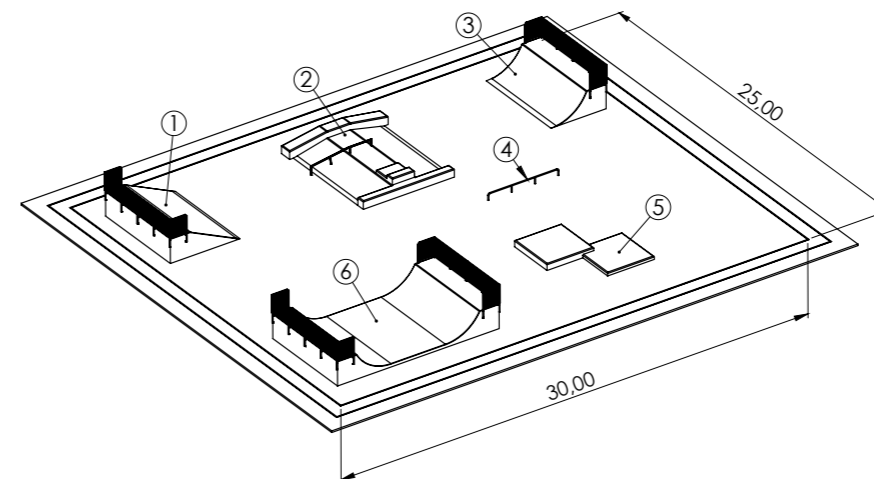

- 1
- 2
- 3
- 4
- 5
- 6

Obstacle name	Height m	Width m	Length m	Height with barrier m
1 Flat bank	1,5	6,0	4,5	2,7
2 Funbox	0,9/0,5	7,3	6,3	
3 Quarterpipe	1,5	6,0	3,6	
4 Grind rail	0,4	0,06	4,0	
5 Grind box combo	0,4/0,2	5,3	5,3	
6 Halfpipe	1,5	6,0	10,4	2,7

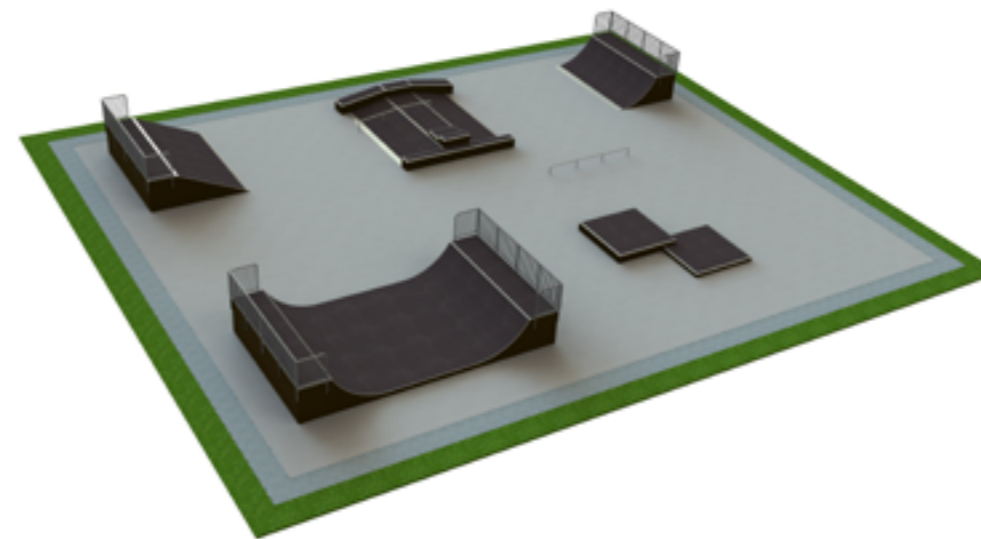

B145



Park area: 700m²
 Riding surface: 160m²
 Dimensions: 35x20x1,5m

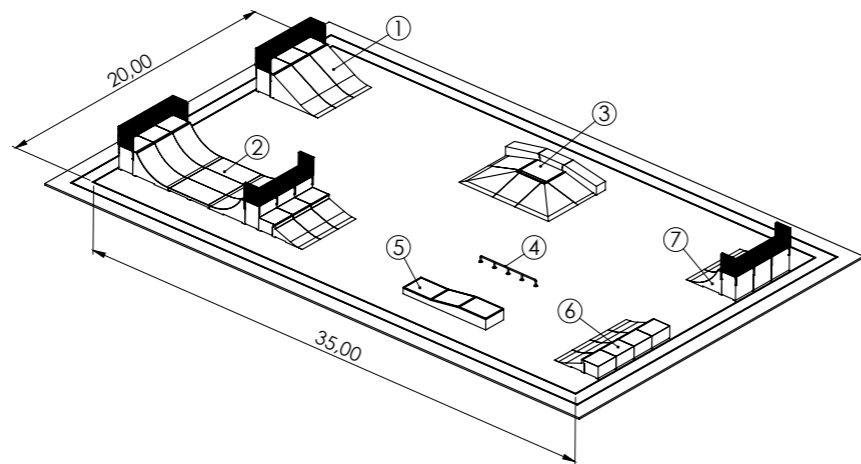

	Obstacle name	Height m	Width m	Length m	Height with barrier m
1	Bank	1,5	4,5	4,5	2,7
2	Halfpipe + bank with sub-box	1,5	4,5	13,3	2,7
3	Funbox	1,0/0,6	4,7	6,6	
4	Grind rail	0,4	0,06	4,0	
5	Grind box	0,6/0,4	1,5	6,0	
6	Bank with sub-box	0,8	6,0	3,2	
7	Quarterpipe	1,5	4,5	3,6	2,7

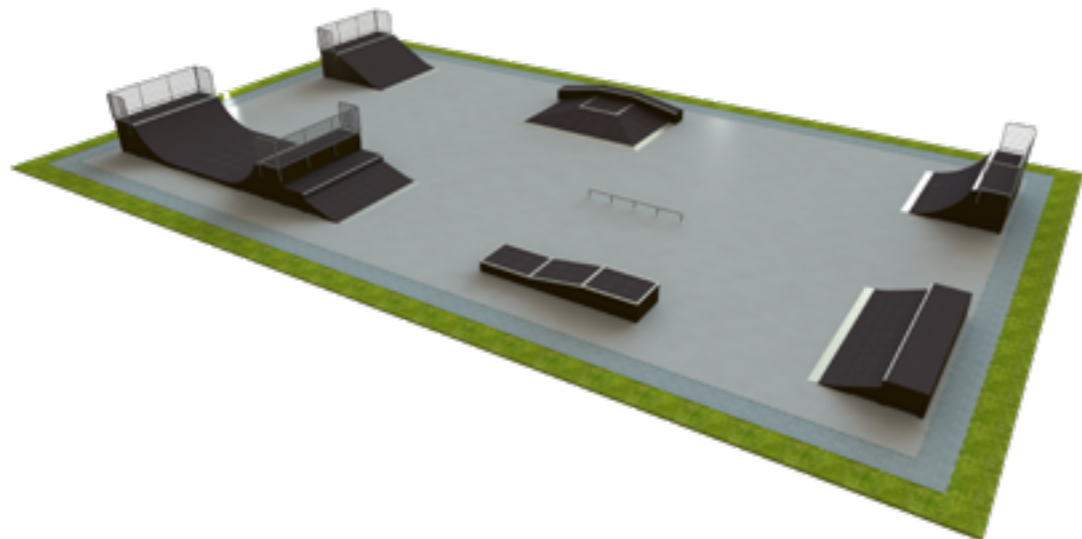

B150



Park area: 400m²
 Riding surface: 183m²
 Dimensions: 40x10x1,5m

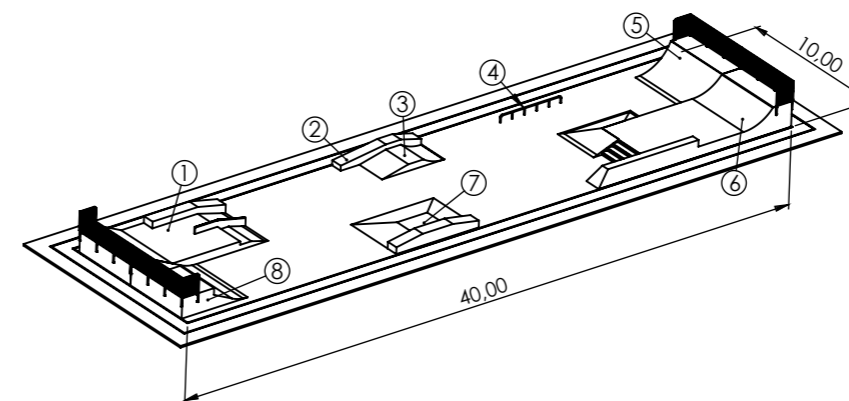

	Obstacle name	Height m	Width m	Length m	Height with barrier m
1	Doubleset combo	0,5/0,9/1,2	4,5	9,2	2,4
2	Grind box	0,7	0,75	5,3	
3	Funbox	0,4	2,0	4,1	
4	Grind rail	0,4	0,06	4,0	
5	Quarterpipe	1,5	4,5	3,6	2,7
6	Doubleset	0,6/1,0/1,5	6,2/4,5	12,7	2,7
7	Funbox	0,4/0,7	4,0	5,5	
8	Bank with sub-box	1,2	4,5	4,4	2,4

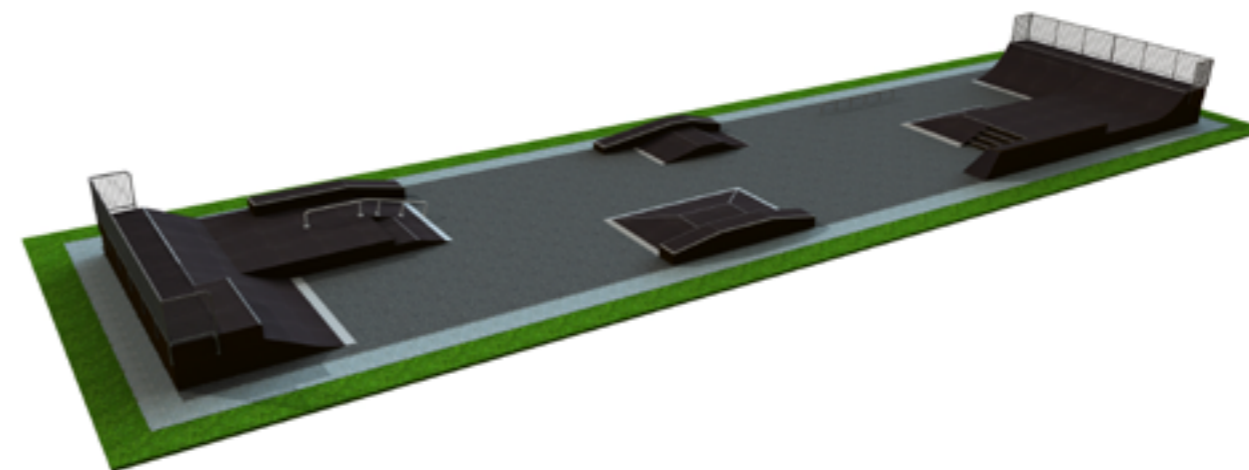

B155



Park area: 700m²
 Riding surface: 196m²
 Dimensions: 35x20x3,5m

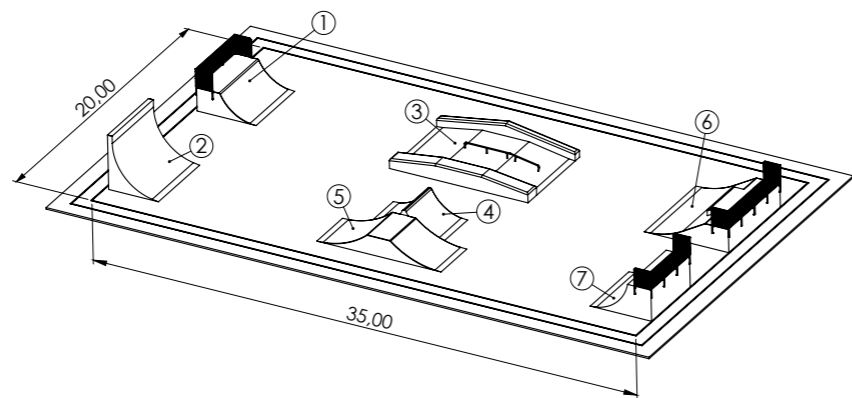

- 1
- 2
- 3
- 4
- 5
- 6
- 7

Obstacle name	Height m	Width m	Length m	Height with barrier m
Quarterpipe	1,5	4,5	3,8	2,7
Wallride	3,5	4,8	3,2	
Funbox	0,5/1,0	6,0	9,0	
Spine	1,5	3,0	4,8	
Flybox	1,2	3,0	8,0	
Bank with drop	1,5	6,0	5,5	2,7
Quarterpipe	2,0	4,5	4,0	3,2

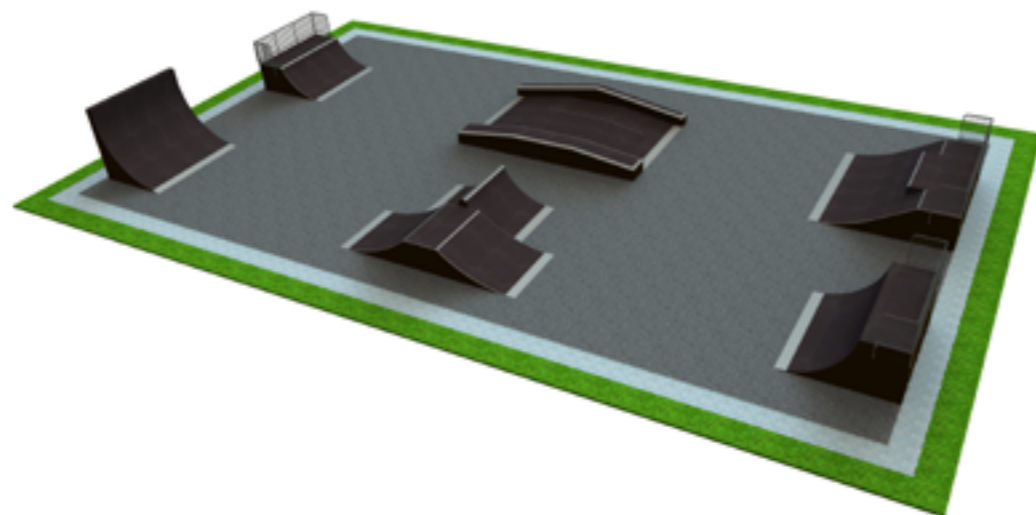

B156



Park area: 295m²
 Riding surface: 145m²
 Dimensions: 45x12x4m

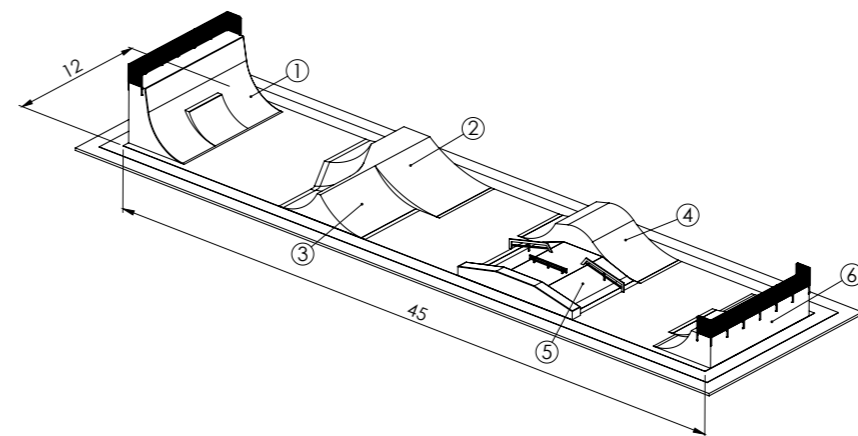

- 1
- 2
- 3
- 4
- 5
- 6

Obstacle name	Height m	Width m	Length m	Height with barrier m
Wallride	4,0	9,0	4,3	5,2
Flybox	1,8	5,0	10,0	
Spine	1,8	5,0	6,7	
Flybox	2,1	3,75	9,5	
Funbox	0,8/1,2	6,25	8,85	
Quarterpipe set	2,0	9,0	5,0	3,2

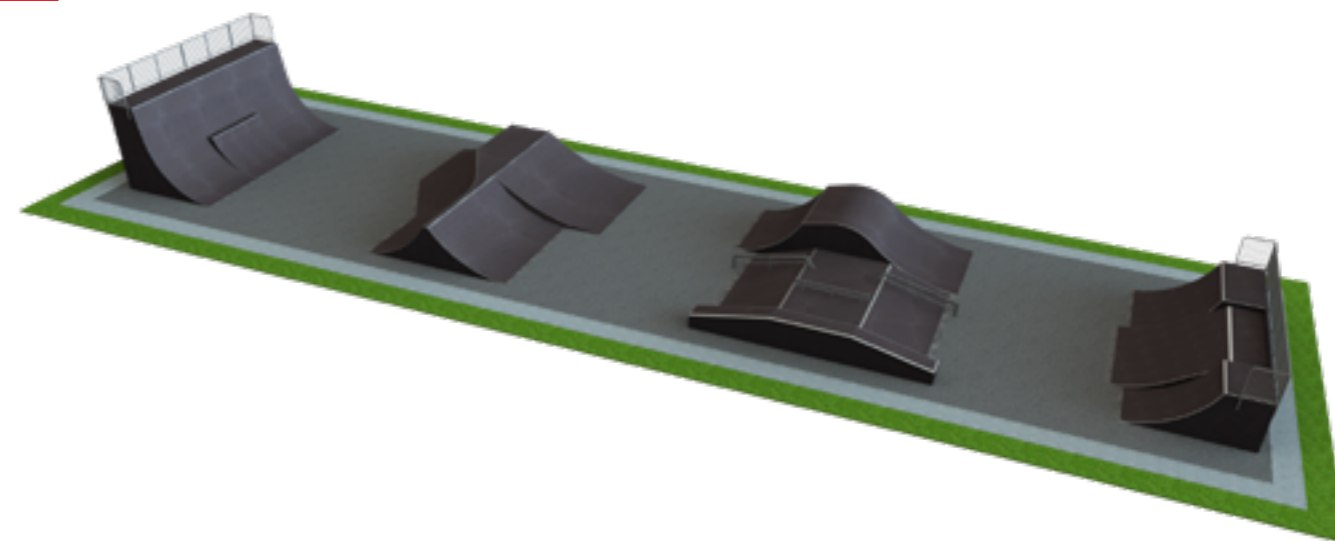

B157



Park area: 450m²
 Riding surface: 243m²
 Dimensions: 30x15x1,8m

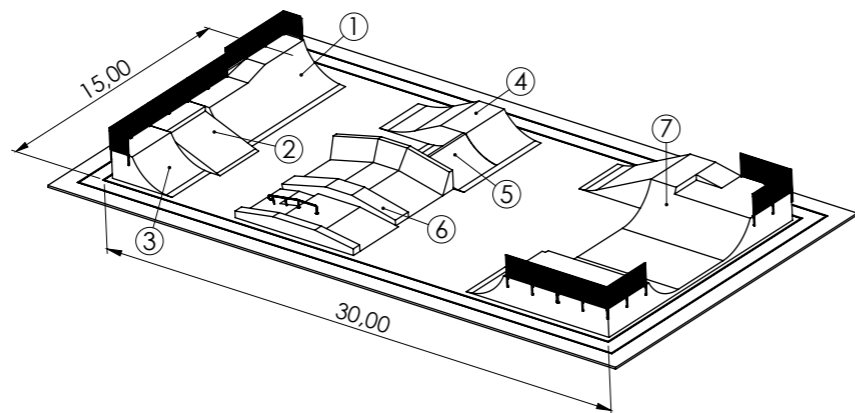

	Obstacle name	Height m	Width m	Length m	Height with barrier m
1	Quarterpipe set	1,8/1,5	7,5	3,6	3,0
2	Flat Bank with drop	1,5	3,0	4,1	2,7
3	Quarterpipe	1,5	3,0	3,6	2,7
4	Flybox	1,2	3,0	7,4	
5	Spine	1,2	3,0	4,4	
6	Funbox set	0,4/0,6/0,9/1,6	8,0	7,0	
7	Halfpipe set	1,8/1,5	10,4	14,3	2,7

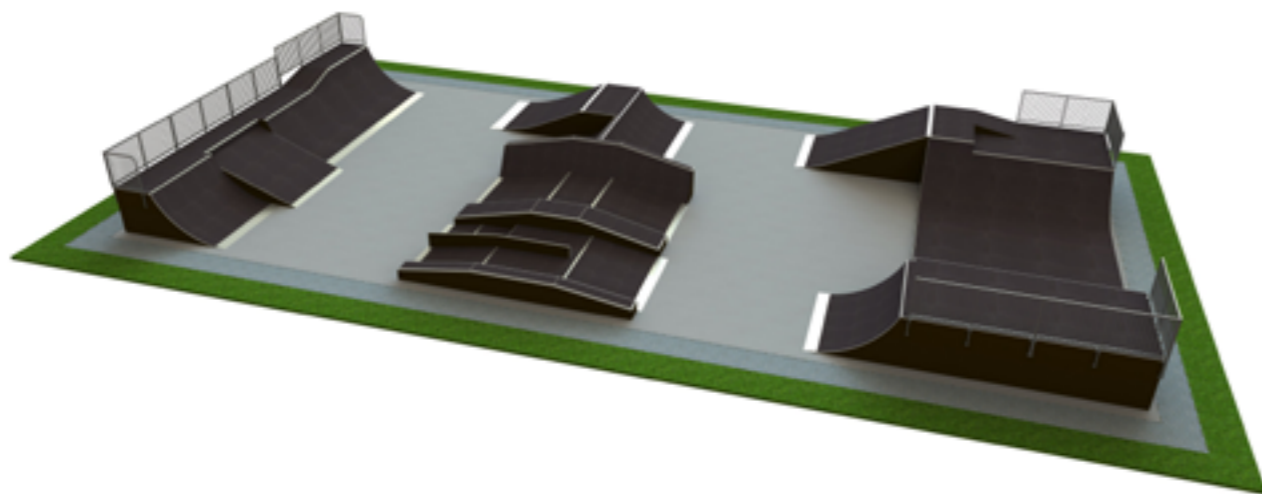

B160



Park area: 700m²
 Riding surface: 209m²
 Dimensions: 35x20x1,7m

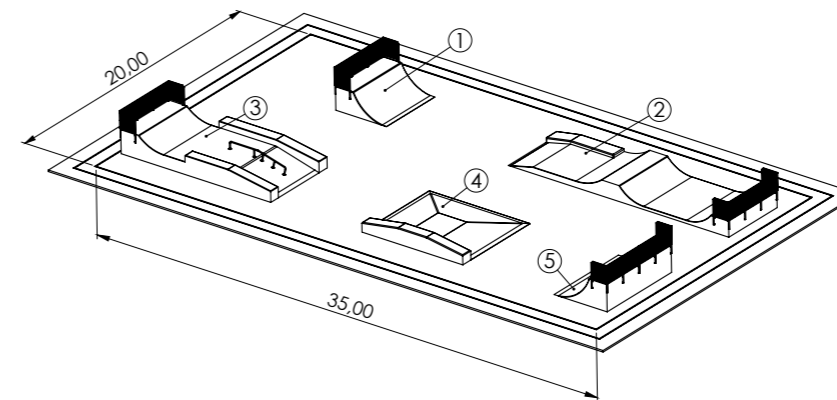

	Obstacle name	Height m	Width m	Length m	Height with barrier m
1	Quarterpipe	1,5	4,5	3,6	2,7
2	Doubleset	1,0	4,5	15,5	2,2
3	Doubleset	1,5/1,2/0,8	4,5	10,5	2,7
4	Funbox	1,0/0,4	6,3	7,1	
5	Quarterpipe	1,7	6,0	3,8	2,9

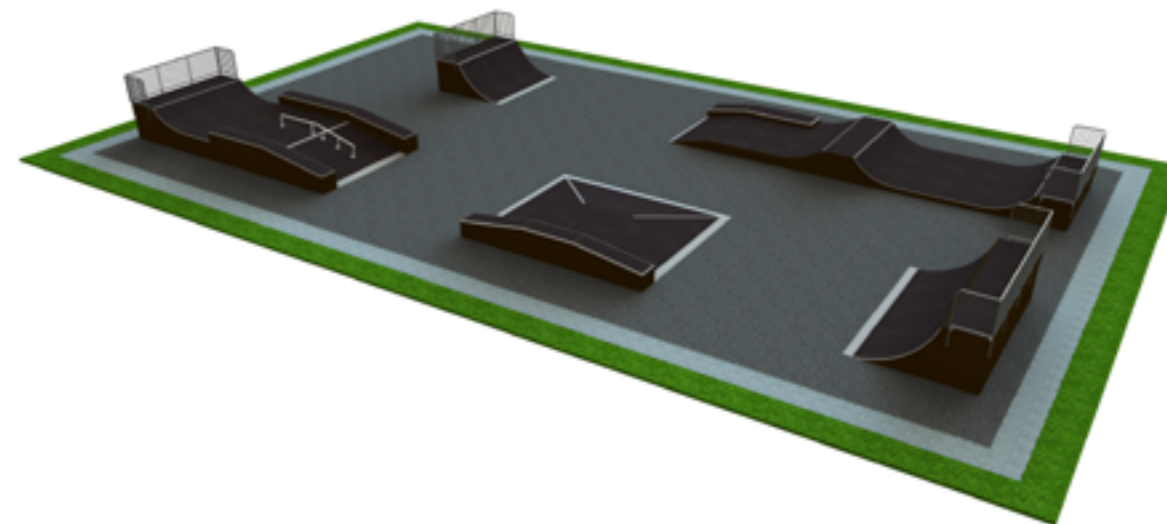

B165



Park area: 700m²
Riding surface: 236m²
Dimensions: 35x20x3m

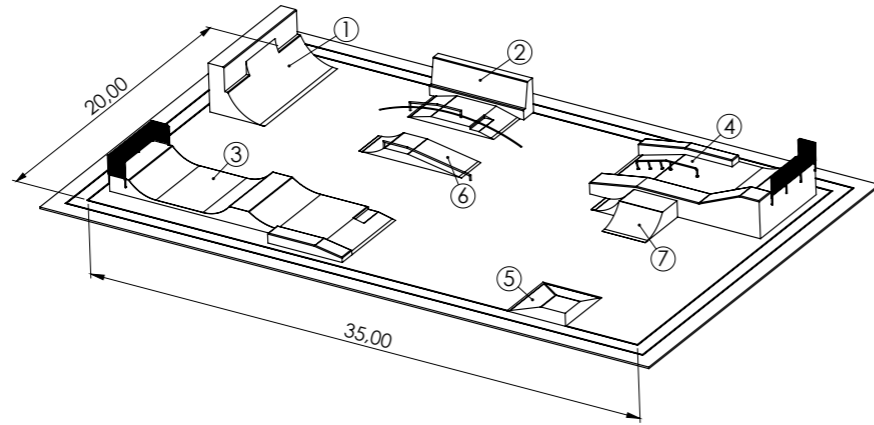

	Obstacle name	Height m	Width m	Length m	Height with barrier m
1	Bank with subbox	3,0	7,5	3,5	
2	Grind box set	0,4/2,1	3,7	9,0	
3	Halfpipe set	1,0/0,6	5,5/4,5	15,5	2,2
4	Doubleset	2,0/2,3/1,2/0,8	5,75	11,0	3,2
5	Pyramid corner	0,8	3,8	3,8	
6	Grind box	1,0/0,6	2,0	7,1	
7	Quarterpipe corner	1,0	3,4	4,6	

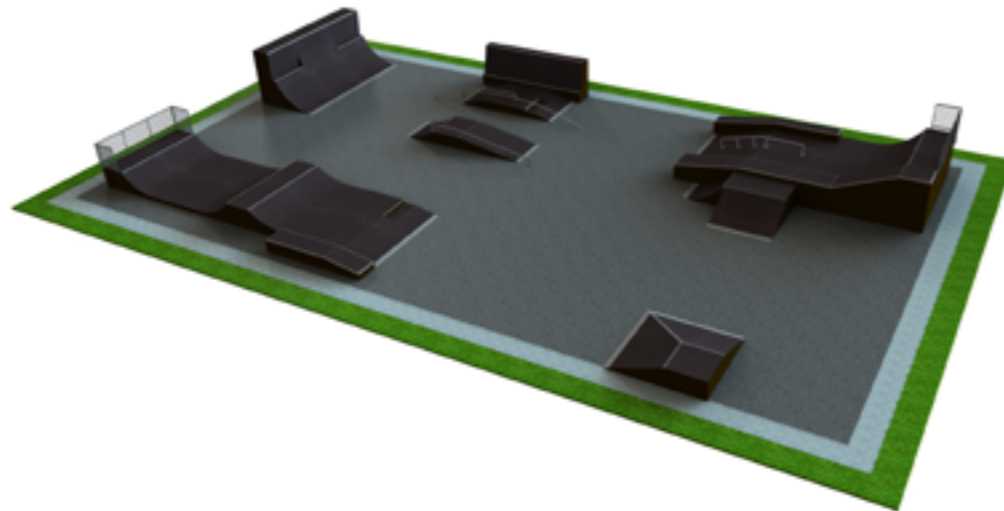

34

B170



Park area: 600m²
Riding surface: 215m²
Dimensions: 30x20x3m

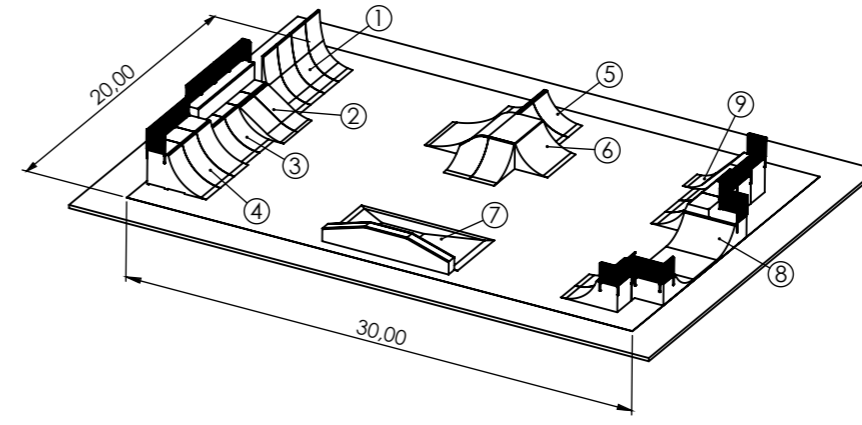

	Obstacle name	Height m	Width m	Length m	Height with barrier m
1	Wallride	3,0	6,0	2,1	
2	Bank with subbox	2,5/1,5	3,0	4,0	3,7
3	Quarterpipe with subbox	2,5/1,5	3,0	3,4	3,7
4	Quarterpipe	2,0	4,5	3,5	3,2
5	Spine	1,5	3,0	4,4	
6	Flybox set	1,5	5,2	7,3	
7	Funbox	0,9/1,5	4,5	7,9	
8	Miniramp set	1,25/1,7	5,0	14,1	2,9
9	Bank	2,0	1,5	4,1	3,2

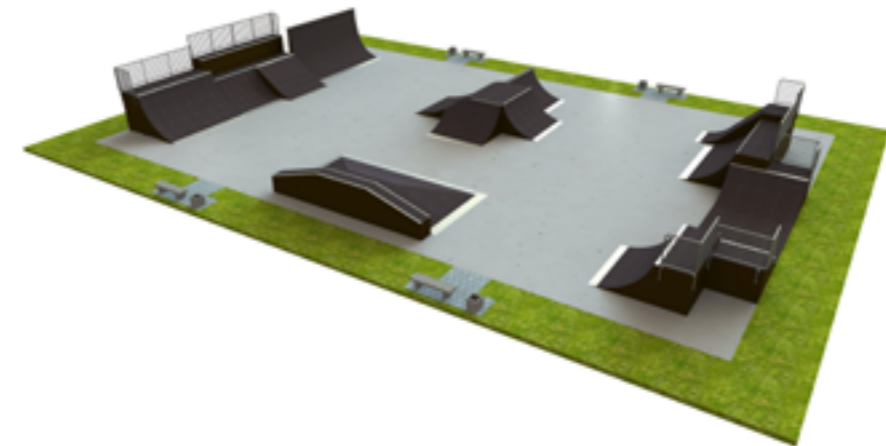

35

B175



Park area: 900m²
Riding surface: 236m²
Dimensions: 60x15x3m

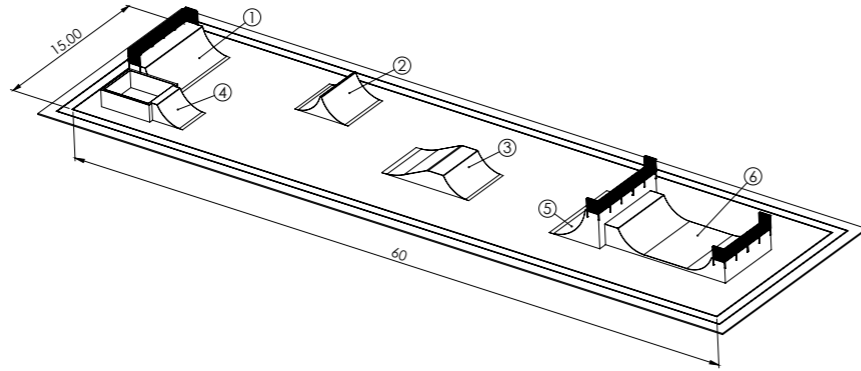

	Obstacle name	Height m	Width m	Length m	Height with barrier m
1	Quarterpipe	2,0	7,5	4,0	3,2
2	Spine	1,8	4,5	5,0	
3	Flybox	1,5	4,5	8,1	
4	Foambox (w/o foam)	1,5	3,75	7,3	
5	Quarterpipe	3,0	7,5	4,7	4,2
6	Miniramp	1,8	6,0	11,1	3,0

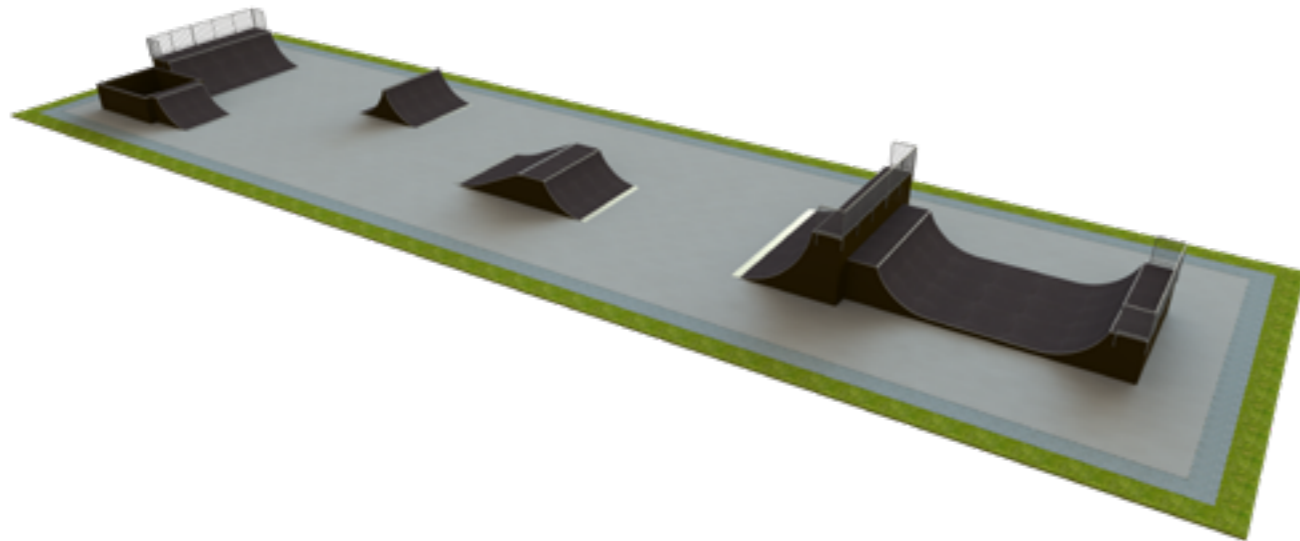

36

B178



Park area: 552m²
Riding surface: 251m²
Dimensions: 46x12x2m

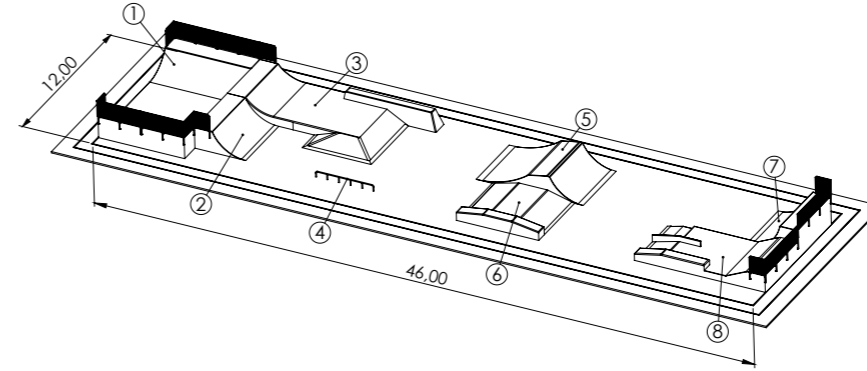

	Obstacle name	Height m	Width m	Length m	Height with barrier m
1	Miniramp	1,5	6,0	10,4	2,7
2	Quarterpipe	1,5	4,5	3,6	
3	Doubleset	1,5/1,0/0,6	6,2	12,8	
4	Grind rail	0,4	0,06	4,0	
5	Flybox	1,5	4,5	7,5	
6	Funbox	0,5/0,9	4,9	5,8	
7	Quarterpipe	2,0	4,5	3,7	3,2
8	Doubleset	1,2/0,9/0,5	4,5	9,1	2,4

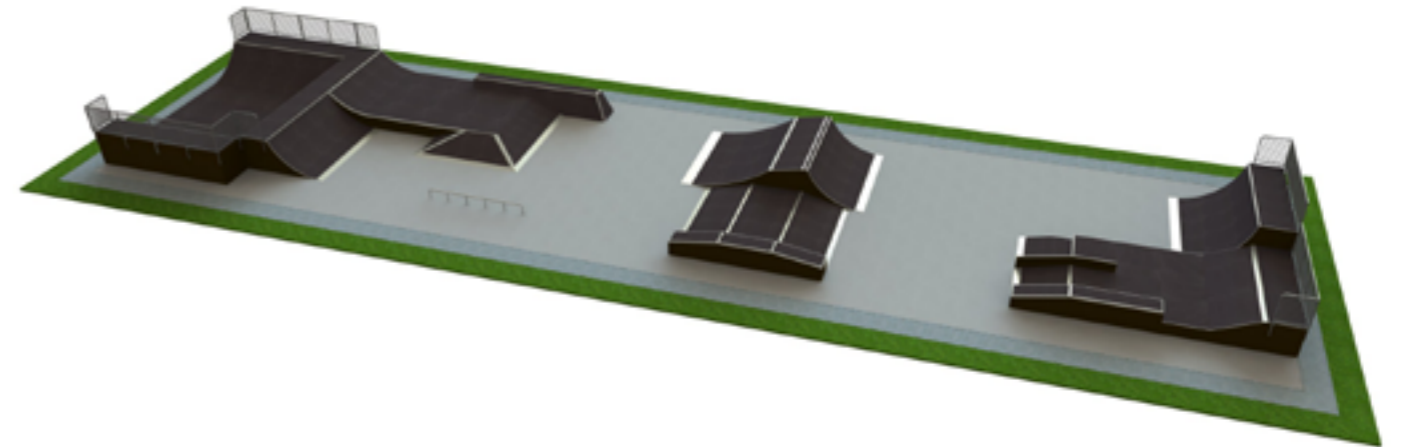

37

B180



Park area: 630m²
Riding surface: 267m²
Dimensions: 35x18x2m

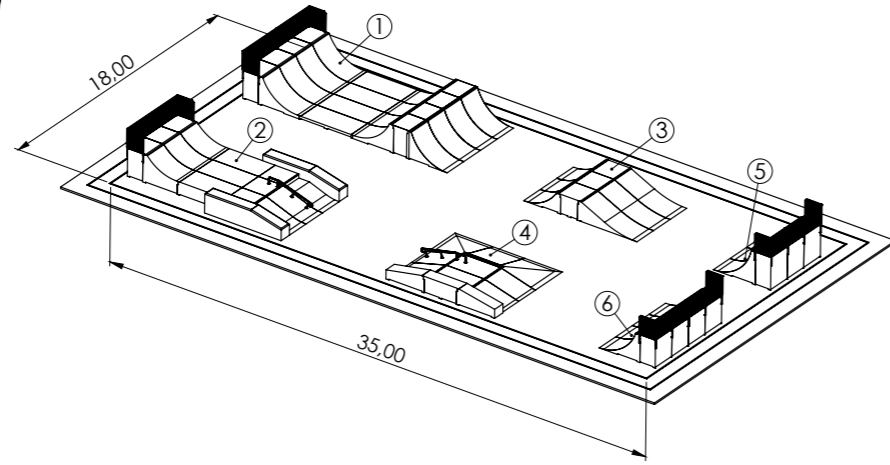

	Obstacle name	Height m	Width m	Length m	Height with barrier m
1	Miniramp with quarterpipe	1,7	6,0	13,5	2,9
2	Doubleset	1,7/1,2/0,8	6,0	10,6	2,9
3	Flybox	1,2	4,5	7,4	
4	Funbox	1,0/0,6	6,2	7,1	
5	Quarterpipe	2,0	4,5	3,7	3,2
6	Quarterpipe	1,7	6,0	3,6	2,9

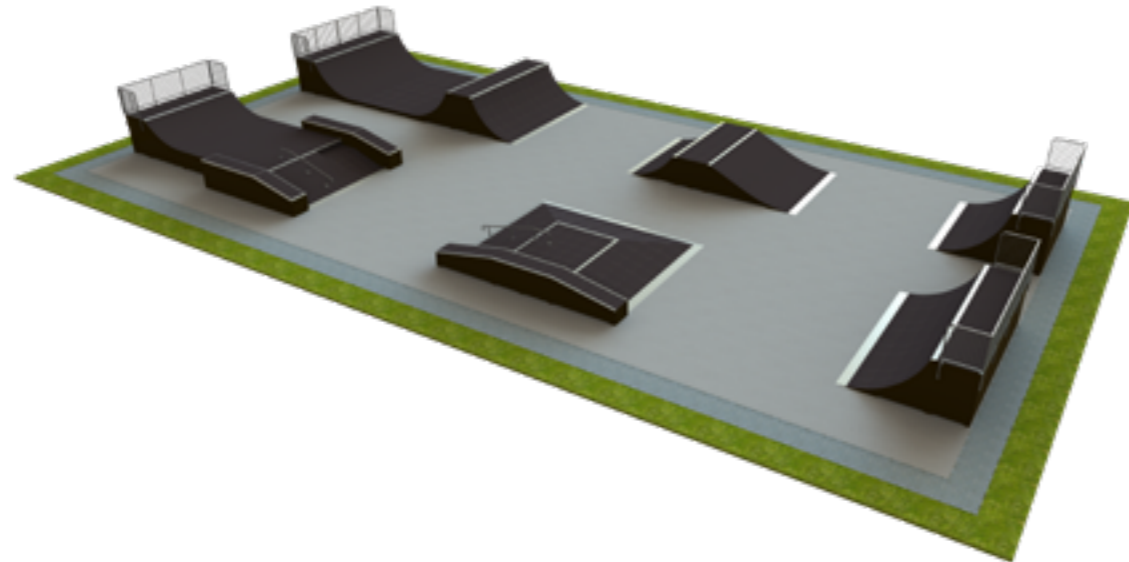

B181



Park area: 630m²
Riding surface: 286m²
Dimensions: 35x18x3,5m

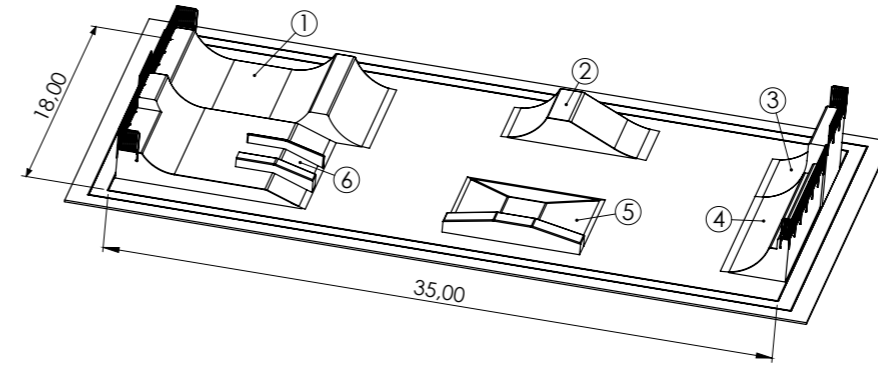

	Obstacle name	Height m	Width m	Length m	Height with barrier m
1	Miniramp with quarterpipe	1,5	7,0	11,7	2,7
2	Flybox	1,5	3,5	7,6	
3	Wallride	3,5	4,5	3,5	4,7
4	Quarterpipe with subbox	2,4	9,0	3,4	3,6
5	Funbox	1,2 /0,6	6,6	7,2	
6	Doubleset	1,65/2,25/1,25/0,75	8,0	10,0	2,9/3,5

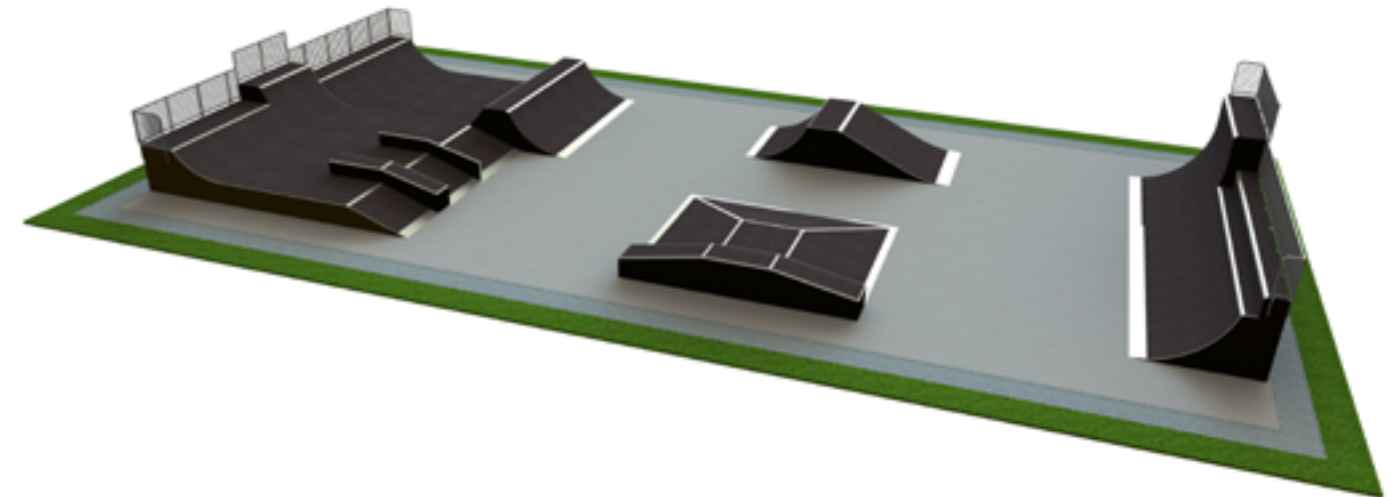

B184



Park area: 760m²
Riding surface: 360m²
Dimensions: 38x20x4m

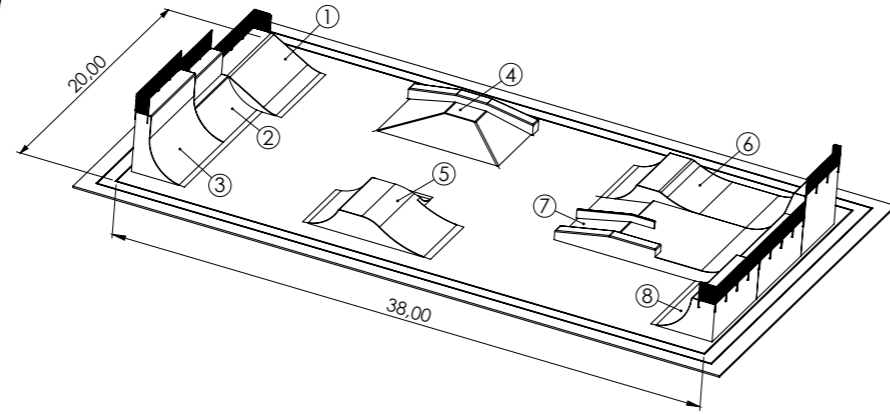

	Obstacle name	Height m	Width m	Length m	Height with barrier m
1	Bank	1,7	6,0	4,8	2,9
2	Quarterpipe with subbox	3,2	4,5	3,5	4,4
3	Wallride	4,0	6,0	3,5	5,2
4	Funbox	0,7/1,2	5,4	8,2	
5	Flybox with quarterpipe	1,5	6,7	8,3	
6	Wallride set with flybox	4,0/1,5/0,8	4,5	13	5,2
7	Double set	2,5/1,3/0,8	6,0	13,2	3,7
8	Quarterpipe	2,5	6,0	4,0	3,7

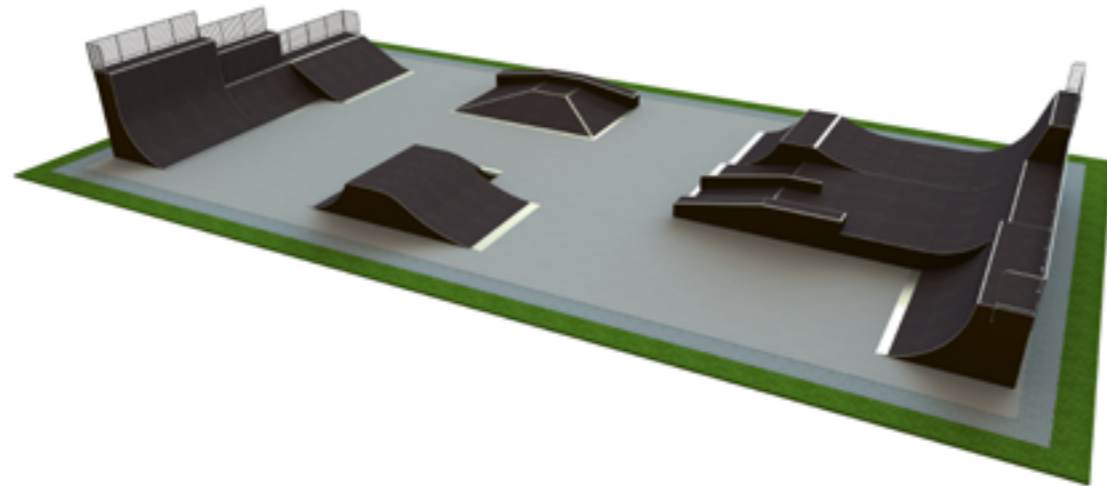

40

B185



Park area: 990m²
Riding surface: 360m²
Dimensions: 30x26x3m

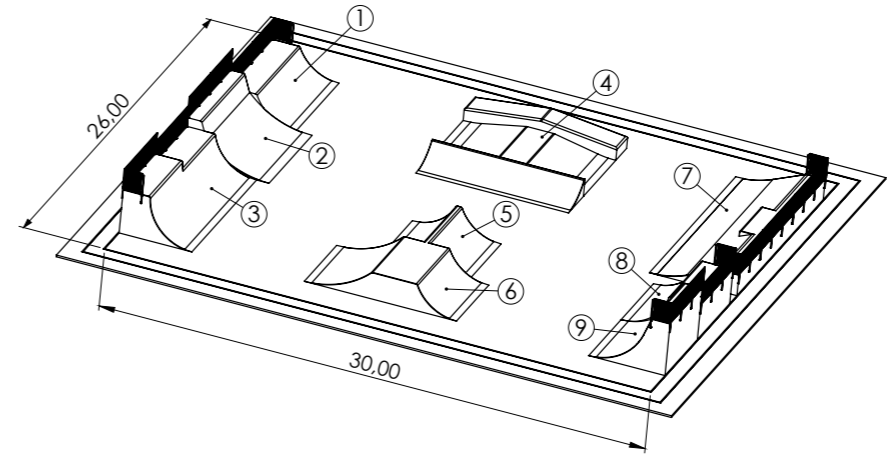

	Obstacle name	Height m	Width m	Length m	Height with barrier m
1	Quarterpipe	1,5	6,0	3,8	2,7
2	Quarterpipe with drop	2,5	6,0	4,7	3,7
3	Quarterpipe set	2,5/2,0	9,0	4,0	3,2/3,7
4	Funbox	0,6/1,2	8,1	8,4	
5	Spine	1,5	4,5	4,9	
6	Flybox	1,5	4,5	8,4	
7	Bank with drop	1,2	12,0	4,8	2,4
8	Quarterpipe	2,0	4,5	4,2	3,2
9	Quarterpipe	3,0	4,5	4,2	4,2

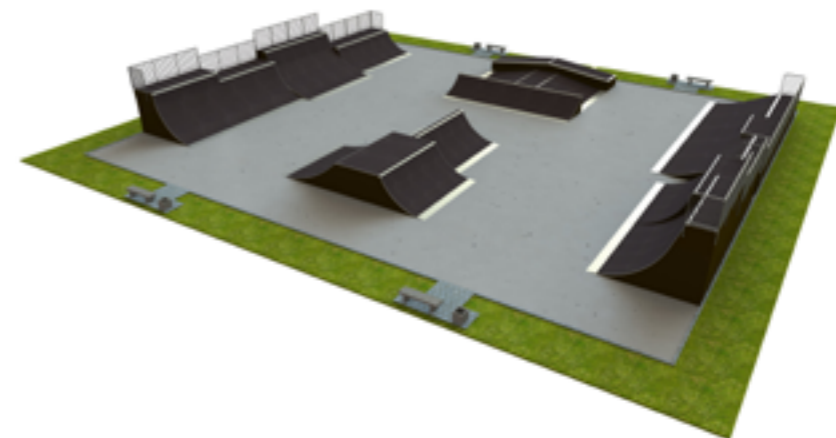

41

B186



Park area: 700m²
Riding surface: 375m²
Dimensions: 35x20x3m

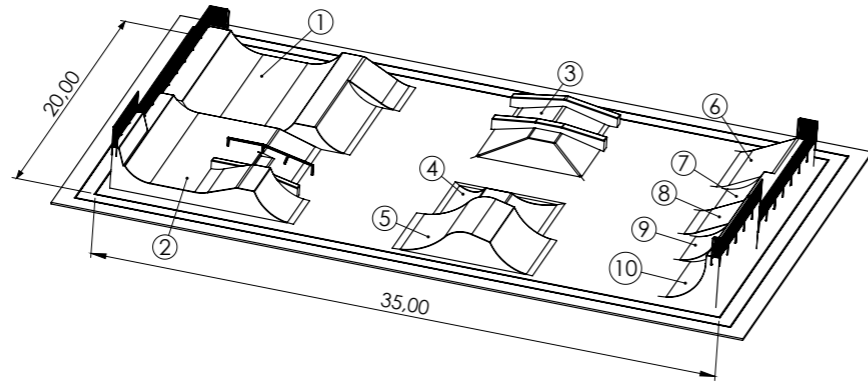

- 1
- 2
- 3
- 4
- 5
- 6
- 7
- 8
- 9
- 10

Obstacle name	Height m	Width m	Length m	Height with barrier m
1 Miniramp + QP + BN	1,25	9,0	11,7	2,55
2 Double set + flybox	2,5/1,5/0,75	9,0	10,3	2,7/3,7
3 Funbox set	1,0/0,6	7,2	6,4	
4 Corner quarterpipe	1,25	4,3	6,2	
5 Flybox	1,8	4,5	7,9	
6 Bank	1,5	4,5	4,5	2,7
7 Quarterpipe	1,5	3,0	3,8	2,7
8 Bank	1,5	3,0	4,5	2,7
9 Quarterpipe with subbox	3,0	3,0	3,8	4,2
10 Quarterpipe	3,0	4,5	3,3	4,2

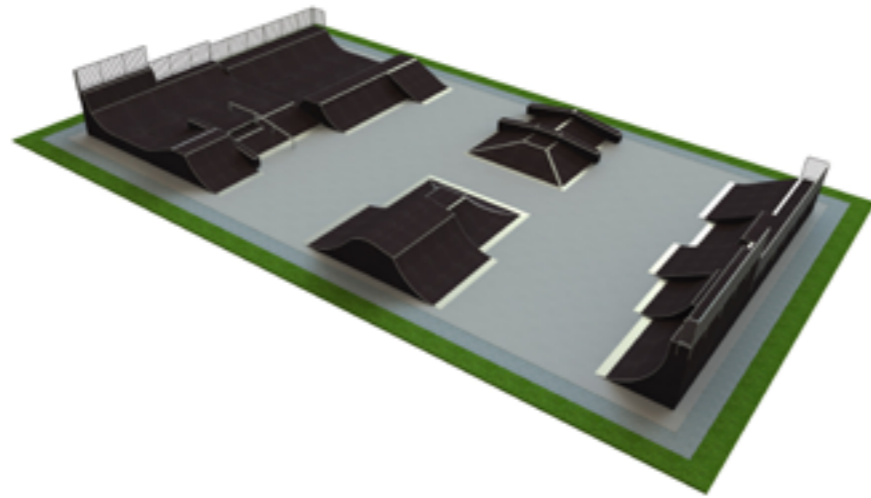

42

B190



Park area: 930m²
Riding surface: 380m²
Dimensions: 50x37x12x2,1m

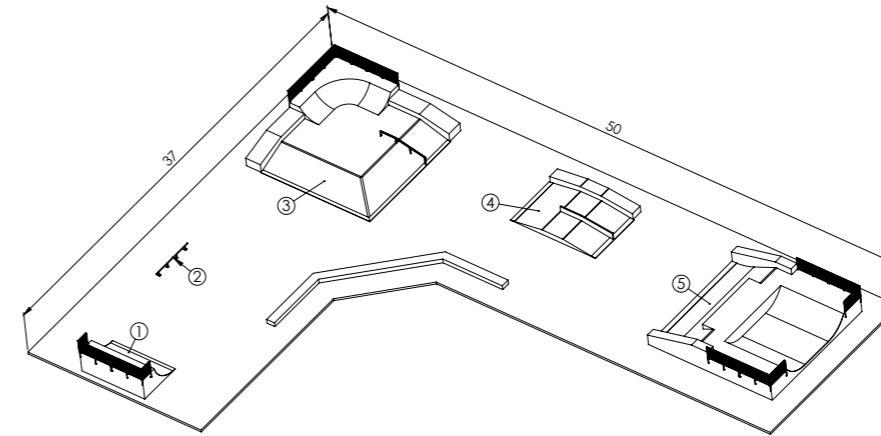

- 1
- 2
- 3
- 4
- 5

Obstacle name	Height m	Width m	Length m	Height with barrier m
1 Quarterpipe	2,0	6,0	4,0	3,2
2 Grind rail	0,4	0,06	4,0	
3 Bowl set	2,0/1,5/1,0	11,9	11,9	3,2
4 Funbox	1,0/0,5	6,0	8,2	
5 Miniramp set + QP	2,1/1,5	11,6	11,9	2,7

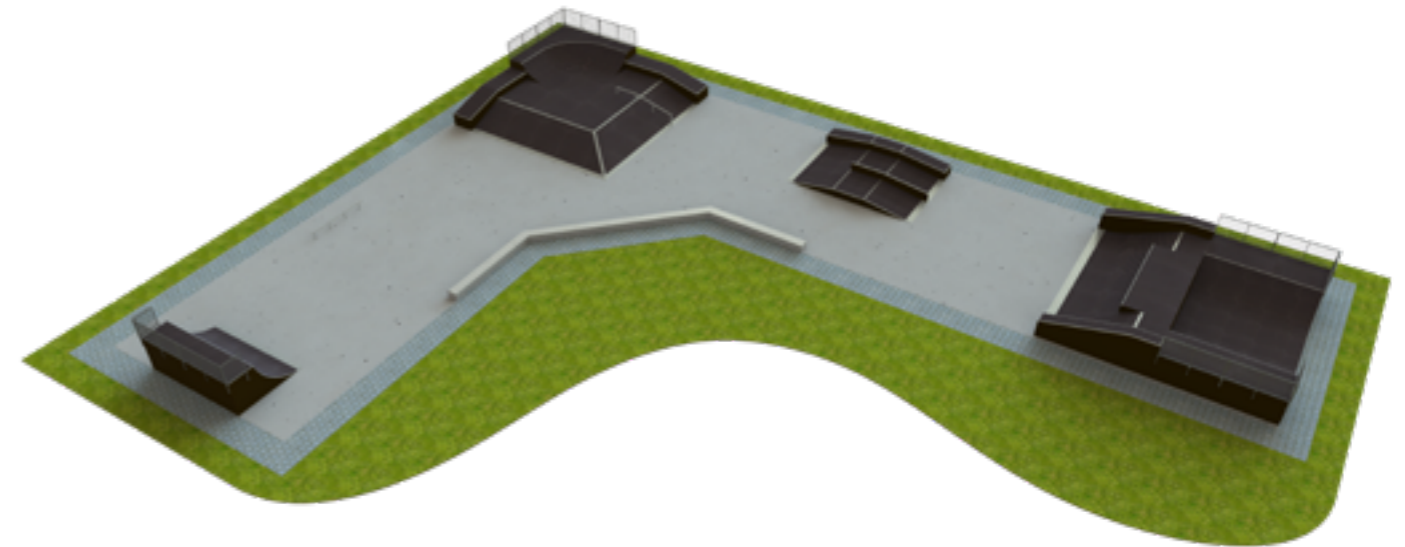

43

B195



Park area: 750m²
Riding surface: 375m²
Dimensions: 30x25x4m

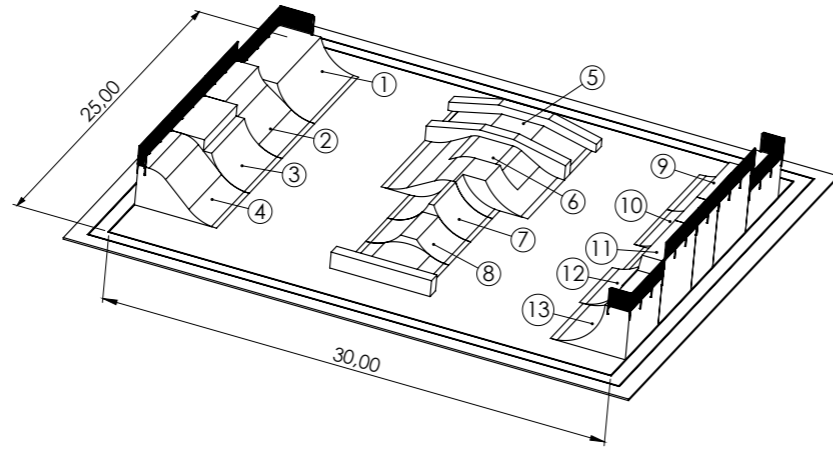

	Obstacle name	Height m	Width m	Length m	Height with barrier m
1	Quarterpipe	1,8	6,0	4,9	3,0
2	Quarterpipe	2,5	4,5	4,9	3,7
3	Quarterpipe with subbox	2,5	4,5	4,9	3,7
4	Roll-in	2,5	4,5	4,9	3,7
5	Funbox	1,6/1,2/0,7	4,5	8,9	
6	Flybox	1,6/1,2	6,0	8,4	
7	Spine	1,6	3,0	5,0	
8	Flybox set	1,0/0,7	6,75	6,0	
9	Quarterpipe	2,5	4,5	4,7	3,7
10	Quarterpipe with subbox	4,0	4,5	4,7	5,2
11	Wallride	4,0	3,0	4,1	5,2
12	Quarterpipe with subbox	4,0	4,5	4,7	5,2
13	Quarterpipe	3,0	4,5	4,5	4,2

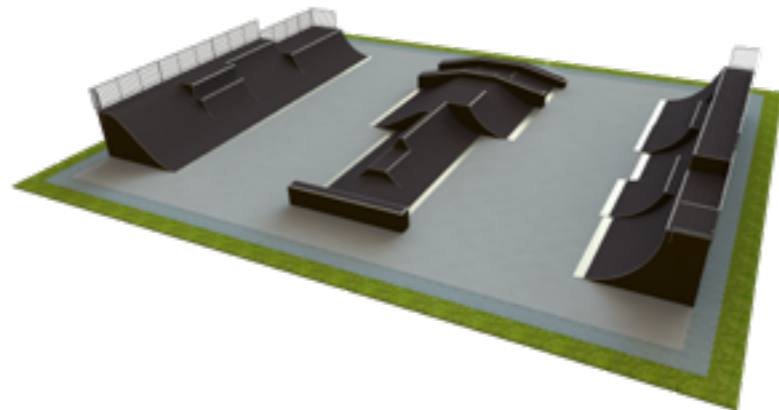

44

B200



Park area: 2000m²
Riding surface: 468m²
Dimensions: 55x40x3,5m

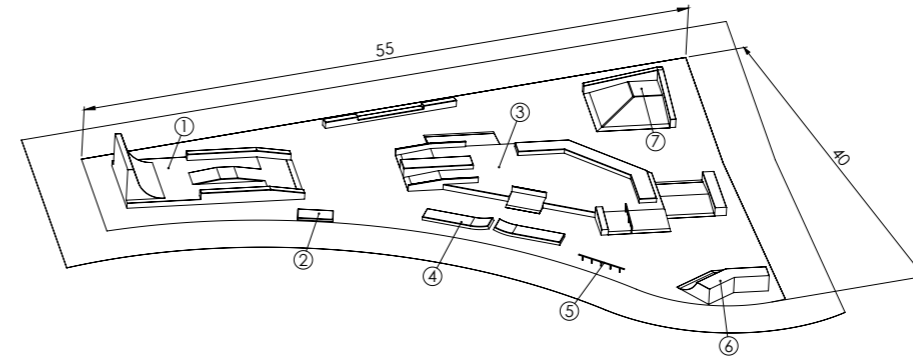

	Obstacle name	Height m	Width m	Length m	Height with barrier m
1	Doubleset	3,5/1,1/0,5	7,1	15,4	
2	Grind box	0,2	1,5	3,0	
3	Funbox set	0,9/0,5	17,7	26,2	
4	Grind box set	0,6/0,3	1,5	12,2	
5	Grind rail	0,4	0,06	4,0	
6	Quarterpipe corner	1,5	8,0	4,0	2,7
7	Pyramid corner	2,0/1,0	6,8	6,8	

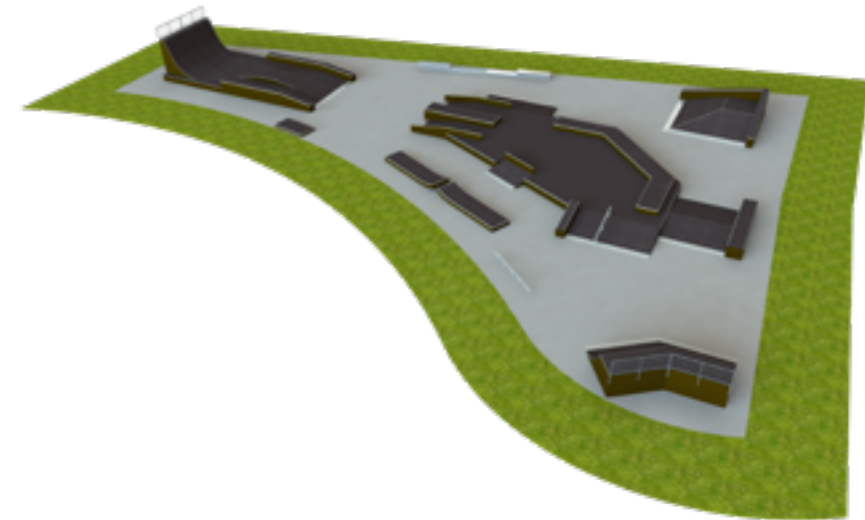

45

B205



Park area: 594m²
Riding surface: 295m²
Dimensions: 33x18x3m

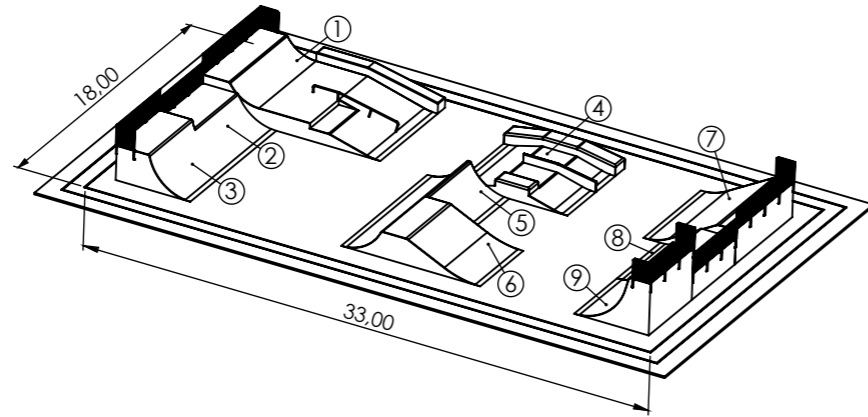

- 1
- 2
- 3
- 4
- 5
- 6
- 7
- 8
- 8

Obstacle name	Height m	Width m	Length m	Height with barrier m
Doubleset	2,0/1,5/1,0	6,75	10,4	3,2
Quarterpipe	1,5	4,5	4,4	2,7
Quarterpipe	2,0	4,5	4,4	3,2
Funbox	1,0/0,5	6,0	6,5	
Spine	1,5	4,5	4,8	
Flybox	1,5	4,5	8,2	
Bank	2,0	6,0	5,4	3,2
Quarterpipe	1,5	4,5	4,4	2,7
Quarterpipe	3,0	4,5	4,4	4,2

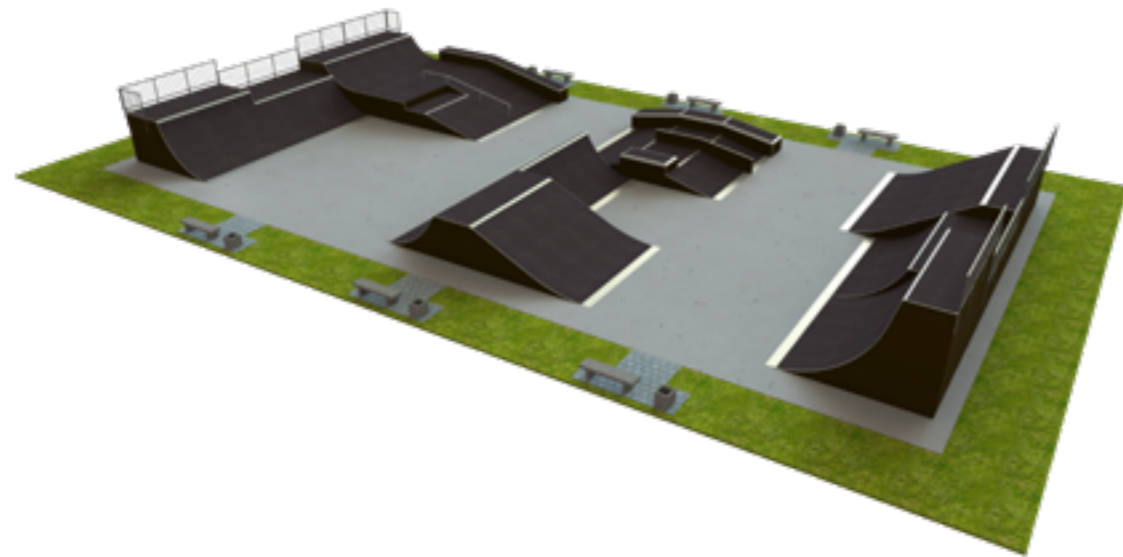

B220



Park area: 2000m²
Riding surface: 512m²
Dimensions: 50x40x3m

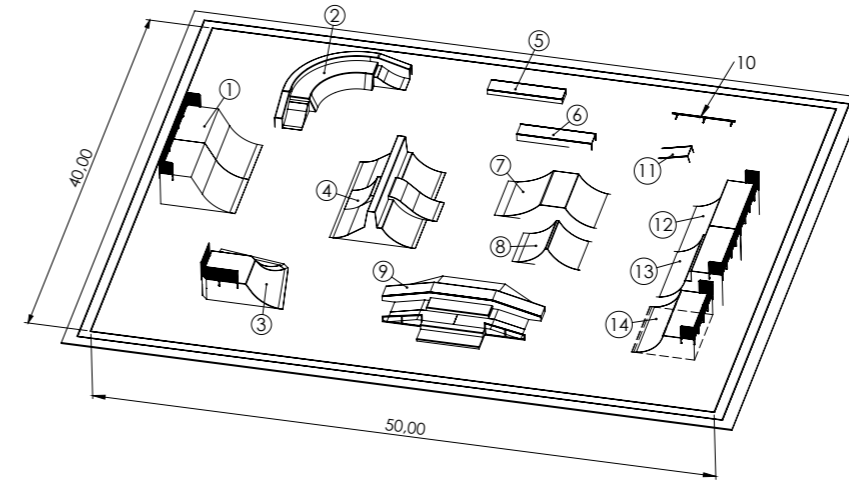

- 1
- 2
- 3
- 4
- 5
- 6
- 7
- 8
- 9
- 10
- 11
- 12
- 13
- 14

Obstacle name	Height m	Width m	Length m	Height with barrier m
Quarterpipe	3,0	9,0	6,0	4,2
Round corner	1,65/1,2	8,9	8,9	
Quarterpipe corner	2,0	6,6	6,6	3,2
Quarterpipe drop set	3,0	10,0	7,7	
Grind box	0,4	1,3	6,0	
Grind box	0,6	1,3	6,0	
Flybox	1,6	4,5	8,4	
Spine	1,7	3,75	5,6	
Funbox	1,4/0,9/0,6	9,6	12,8	
Grind rail	0,4	0,06	5,0	
Kicker	0,6	1,3	2,5	
Quarterpipe	3,0	6,0	5,5	4,2
Quarterpipe with subbox	3,0	6,0	5,6	4,2
Quarterpipe	2,0	6,0	5,1	3,2

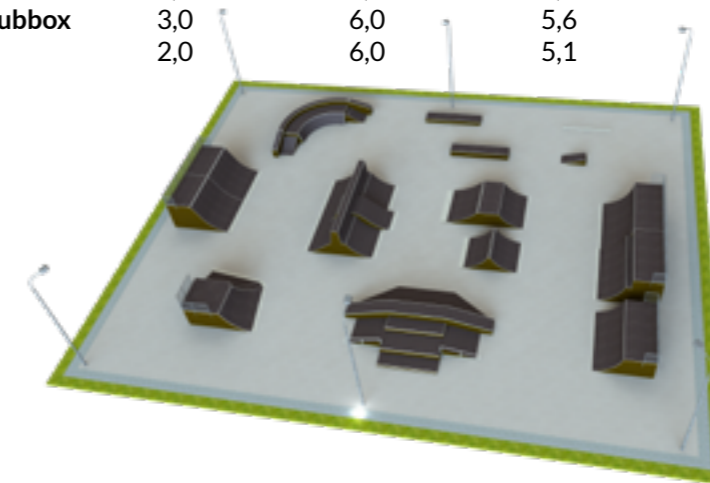

B230



Park area: 940m²
Riding surface: 580m²
Dimensions: 47x20x3,5m

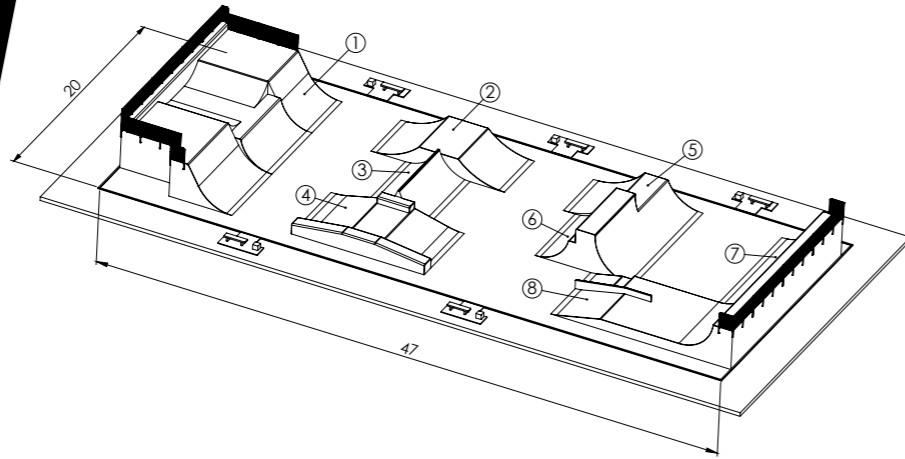

	Obstacle name	Height m	Width m	Length m	Height with barrier m
1	Miniramp set	3,5/3,0/2,0	16,5	9,3	4,7
2	Flybox	1,5	4,5	10	
3	Spine	1,8	6,0	5,0	
4	Funbox	1,3/0,8	6,0	10,2	
5	Flybox	1,8	4,5	8,4	
6	Flybox	3,1	6,0	7,5	
7	Quarterpipe	3,0	10,5	4,5	4,2
8	Double set	3,0	6,0	13,7	4,2

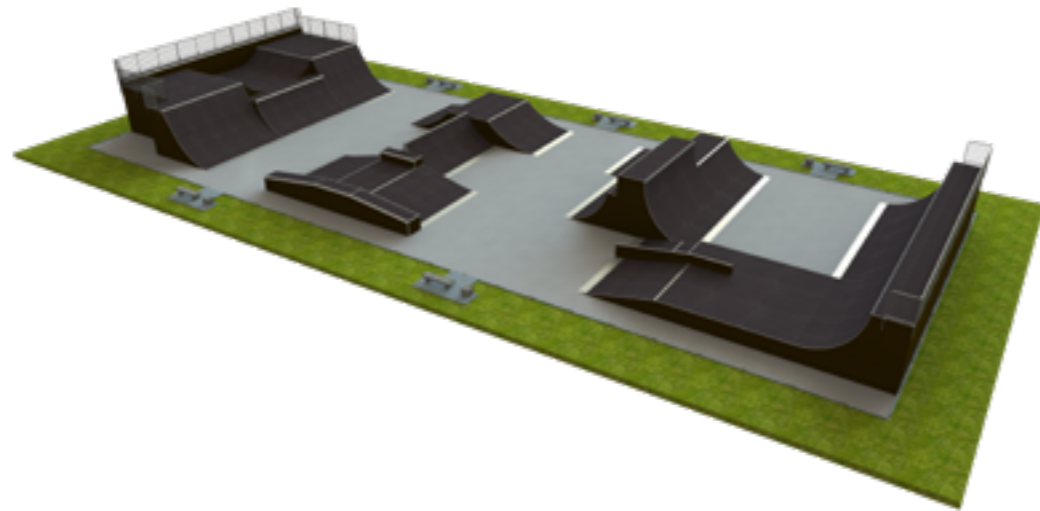

48

B235



Park area: 1140m²
Riding surface: 360m²
Dimensions: 55x33x1,8m

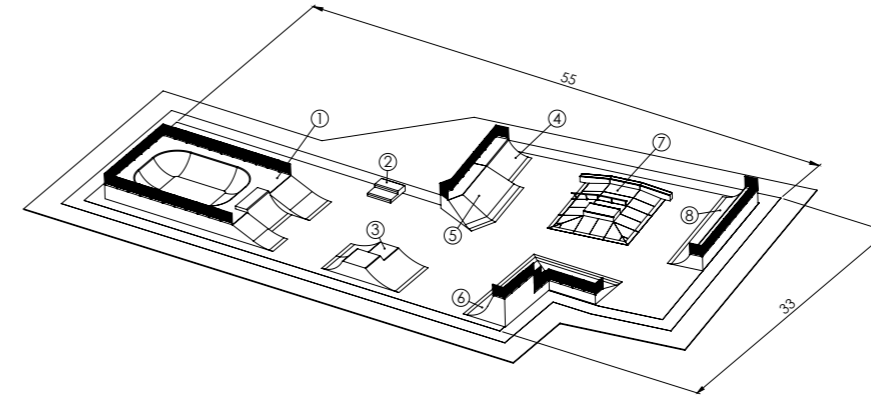

	Obstacle name	Height m	Width m	Length m	Height with barrier m
1	Bowl set	1,8/1,5	10,0	18,2	2,7
2	Grind box	0,3/0,6	2,5	2,5	
3	Flybox set	1,5/1,2	5,0	8,4	
4	Quarterpipe	1,5	5,0	3,6	2,7
5	Bank corner	1,5	8,7	5,0	2,7
6	QP+BN corner	1,0/3,0	9,6	12,0	2,2/4,2
7	Funbox	1,0/0,5	9,0	9,0	
8	Quarterpipe	1,5	12,5	3,6	2,7

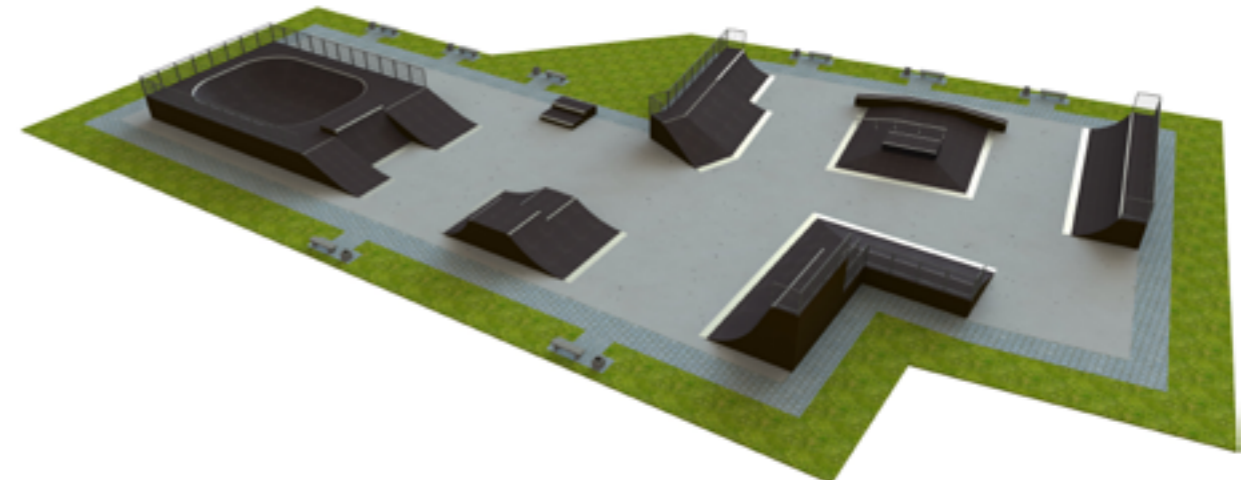

49

B242



Park area: 1800m²
 Riding surface: 760m²
 Dimensions: 62x43x3,5m

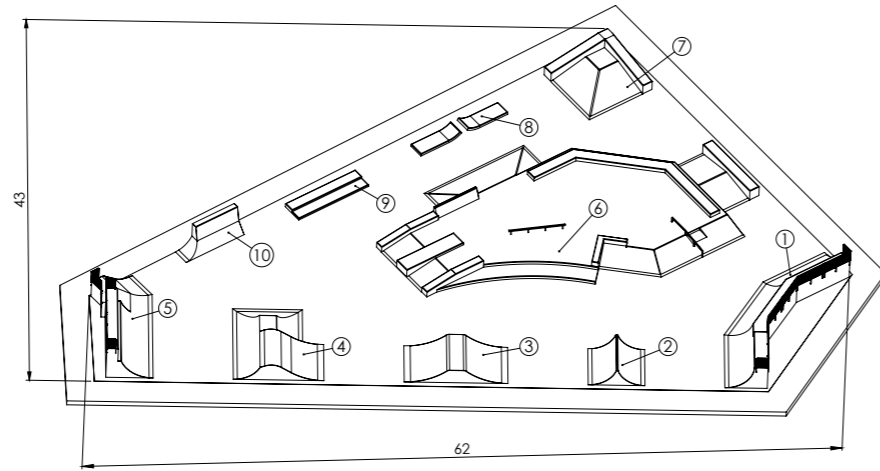

- 1
- 2
- 3
- 4
- 5
- 6
- 7
- 8
- 9
- 10

Obstacle name	Height m	Width m	Length m	Height with barrier m
1 Quarterpipe corner	2,5/2,0	19,0	7,5	3,7
2 Spine	1,8	4,5	5,0	
3 Flybox	1,5	4,5	9,1	
4 Flybox set	1,8	8,8	7,9	
5 Wallride + corner bank	3,5/1,8	12,5	5,2	4,7/3,0
6 Funbox set	1,6/1,0/0,6	31,0	20,0	
7 Pyramid corner	2,0/1,0	6,8	6,8	
8 Grind box set	0,6/0,25	1,5	9,4	
9 Grind box	0,4/0,2	2,0	7,5	
10 Wallride	2,5	6,3	1,6	

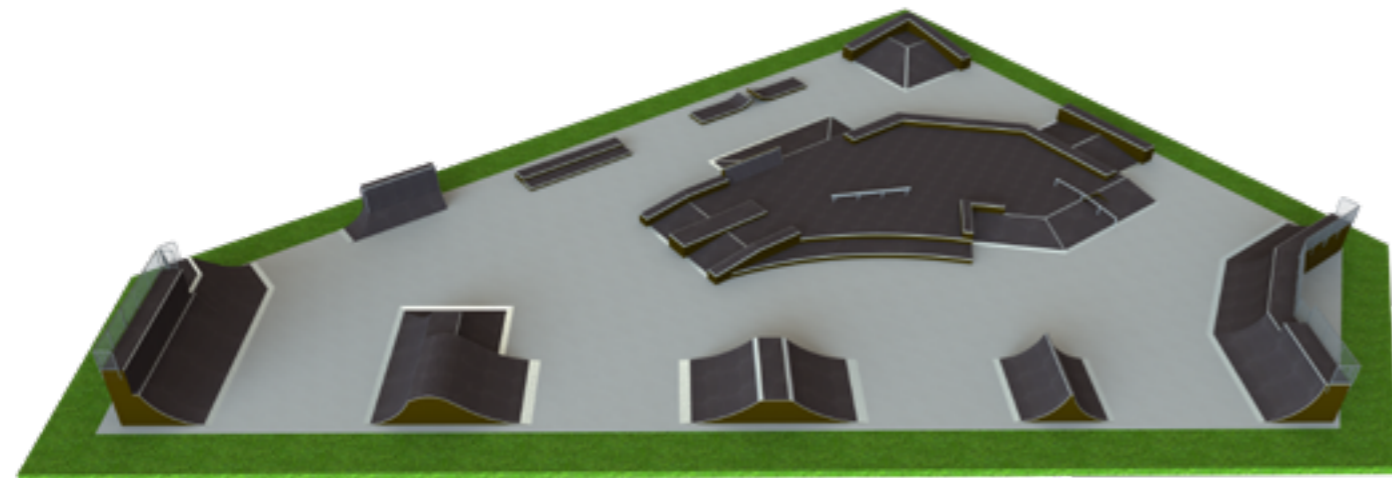

Plaza

Street Plaza skateparks is a new favourite trend among city architects and skaters. They are designed to improve skating experience on the street. The obstacles are styled to replicate urban architecture and movables like stairs, railings, benches. These skateparks are focused on sliding and jumping, easy to use also by non-professionals. The elements are small but offer a lot of fun and can be used by different means of riding. Plaza series skateparks are available in 4 different material versions: BASE, BASE+, STEEL and STEEL PRO.



PLZ010



Park area: 300m²
 Riding surface: 49m²
 Dimensions: 25x12x0,6m

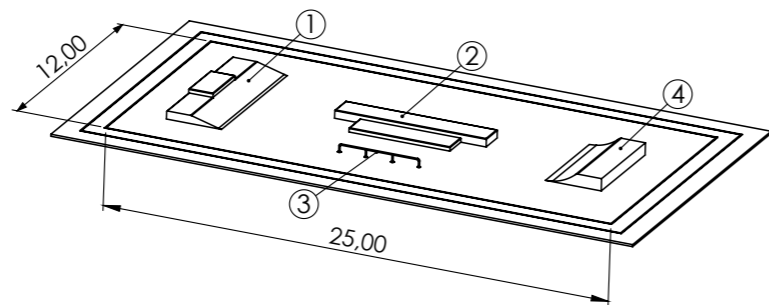

	Obstacle name	Height m	Width m	Length m	Height with barrier m
1	Bank set	0,4(0,6)	7,5	2,7	
2	Grind box	0,4(0,2)	2,4	7,5	
3	Grind rail	0,4	0,06	4,0	
4	Quarterpipe	0,6	5,0	2,7	

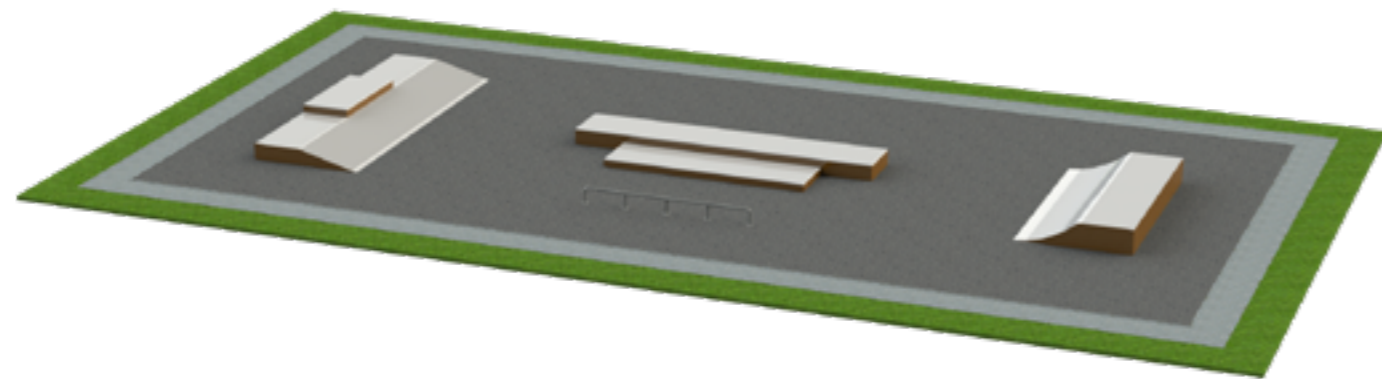

PLZ020



Park area: 300m²
 Riding surface: 49m²
 Dimensions: 25x12x0,8m

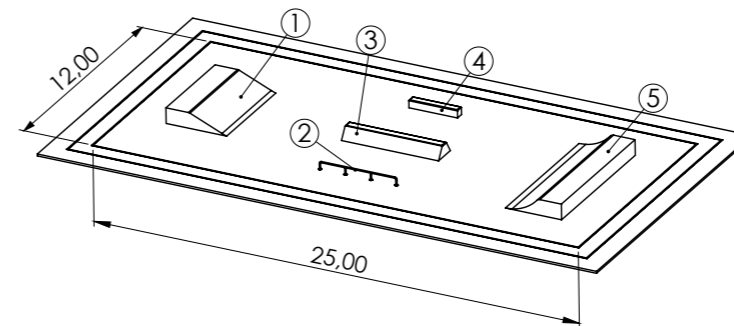

	Obstacle name	Height m	Width m	Length m	Height with barrier m
1	Bank	0,8	5,0	3,1	
2	Grind rail	0,4	0,06	4,0	
3	Grind box	0,6	1,2	5,0	
4	Grind box	0,4	0,4	2,5	
5	Quarterpipe	0,8	7,5	2,8	

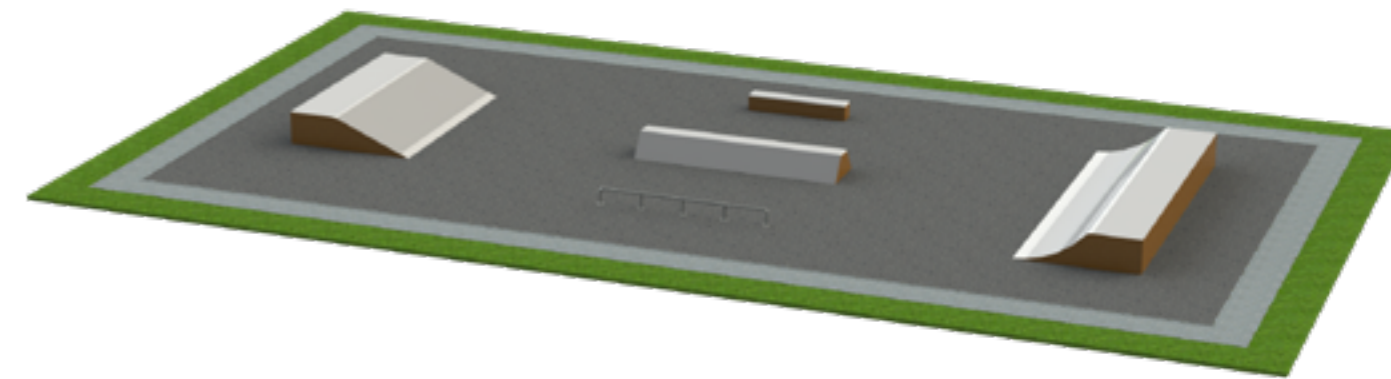

PLZ030



Park area: 364m²
Riding surface: 58m²
Dimensions: 26x14x0,6m

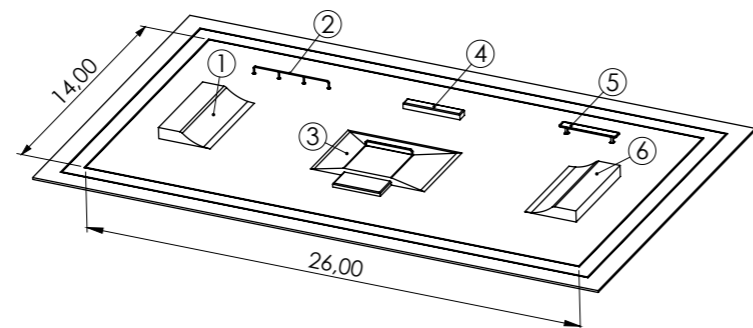

	Obstacle name	Height m	Width m	Length m	Height with barrier m
1	Quarterpipe	0,6	5,0	2,7	
2	Grind rail	0,4	0,06	4,0	
3	Funbox	0,4(0,2)	5,5	6,0	
4	Grind box	0,4	0,4	2,5	
5	Bench	0,45	0,5	3,0	
6	Quarterpipe	0,6	5,0	2,7	

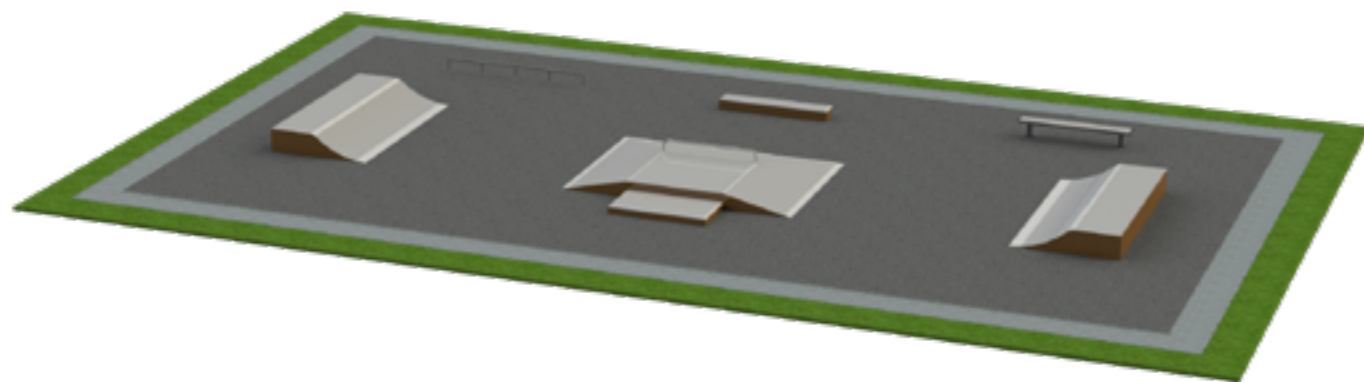

56

PLZ040



Park area: 364m²
Riding surface: 78m²
Dimensions: 26x14x1,1m

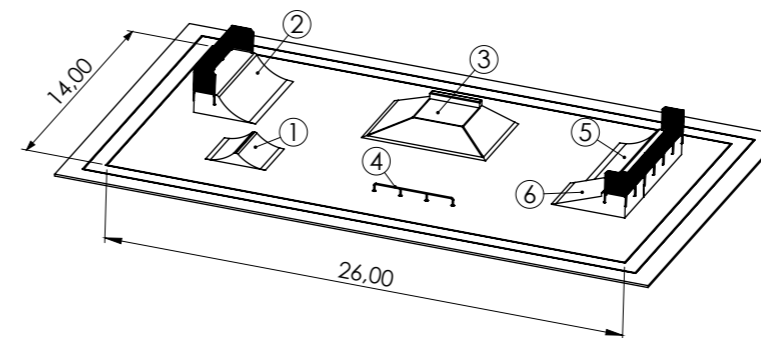

	Obstacle name	Height m	Width m	Length m	Height with barrier m
1	Spine	0,6	2,5	3,0	
2	Quarterpipe	1,1	5,0	3,1	2,3
3	Funbox	0,6(0,9)	4,3	6,2	
4	Grind rail	0,4	0,06	4,0	
5	Quarterpipe	1,1	5,0	3,1	2,3
6	Bank	1,1	2,5	3,6	2,3

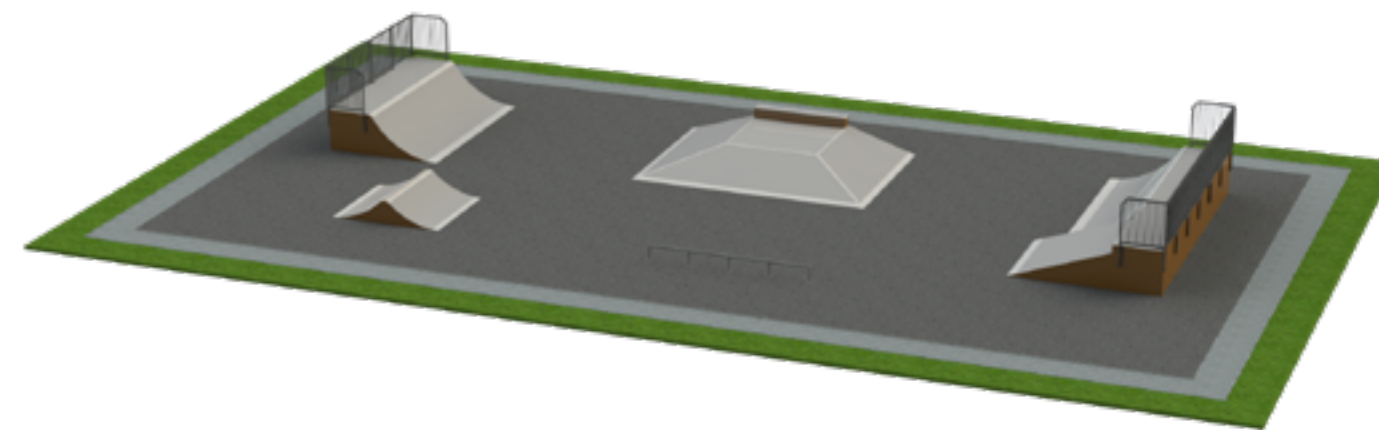

57

PLZ050



Park area: 364m²
 Riding surface: 42m²
 Dimensions: 26x14x0,6m

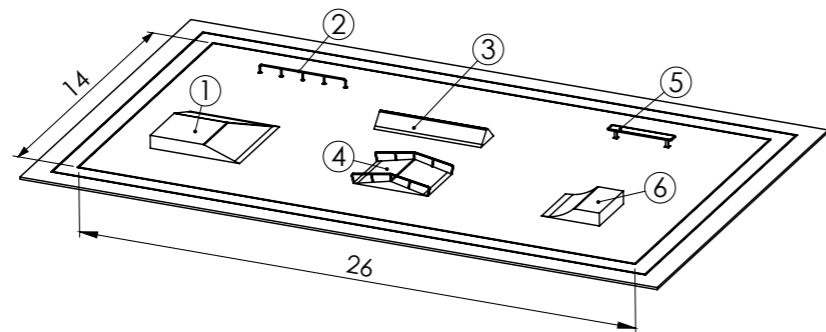

	Obstacle name	Height m	Width m	Length m	Height with barrier m
1	Corner	0,6	4,1	4,1	
2	Grind rail	0,4	0,06	4,0	
3	Grind-corner	0,6	1,3	5,0	
4	Funbox	0,4	2,5	3,5	
5	Bench	0,45	0,5	3,0	
6	Quarterpipe	0,6	2,5	2,7	

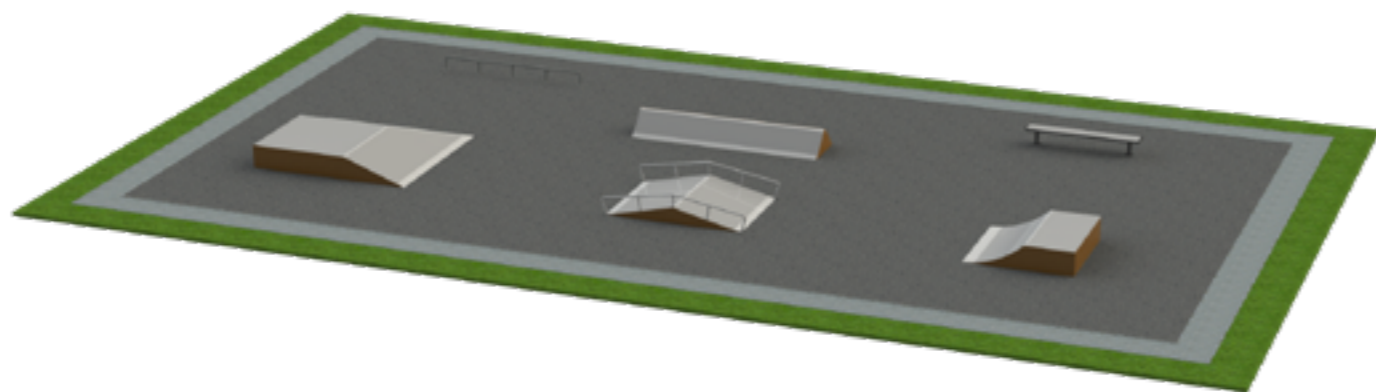

58

PLZ060



Park area: 700m²
 Riding surface: 160m²
 Dimensions: 35x20x1,1m

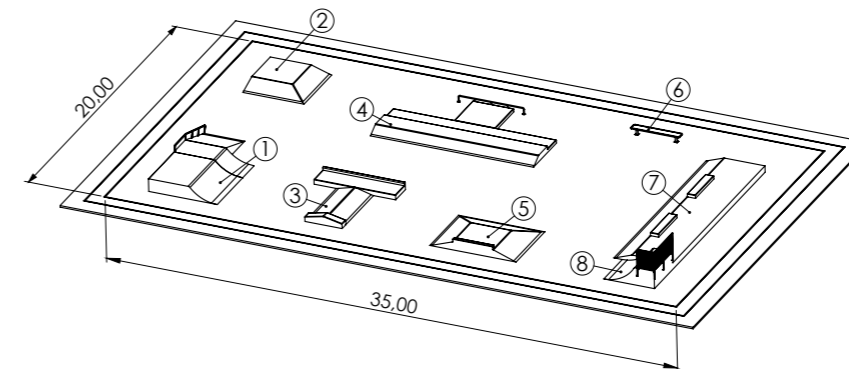

	Obstacle name	Height m	Width m	Length m	Height with barrier m
1	Quarterpipe funbox	0,8	7,5	4,1	
2	Corner pyramid	0,4	3,7	3,7	
3	Small flybox	0,3(0,6)	5,5	5,0	
4	Grind box combo	0,4	10,0	5,6	
5	Funbox	0,5(0,7)	4,0	5,3	
6	Bench	0,45	0,5	3,0	
7	Bank set	0,4(0,6)	12,5	3,6	
8	Quarterpipe	1,1	2,5	3,1	2,3

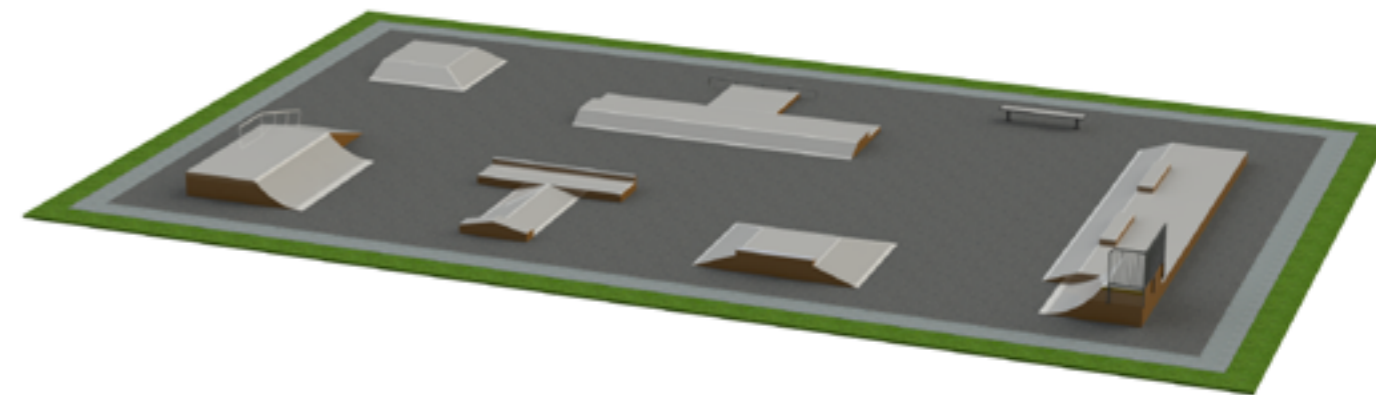

59

Mono

MONO type skateparks have a unique monolithic structure. They can be installed anywhere, even to surfaces without asphalt. The entire structure is installed on concrete pillars standing 20 – 50 cm from the ground. The riding surface of MONO skateparks is made from uniform material, it has no transitions from riding surface to asphalt. The latter ensures both smoother and faster speed while riding as well as greater safety and means fewer injuries in the event of a fall. MONO skateparks are available in two different material combinations: BASE and BASE+.



M500



Riding surface: 203m²
 Dimensions: 24x9x1,2m
 Platform height: 0,5m

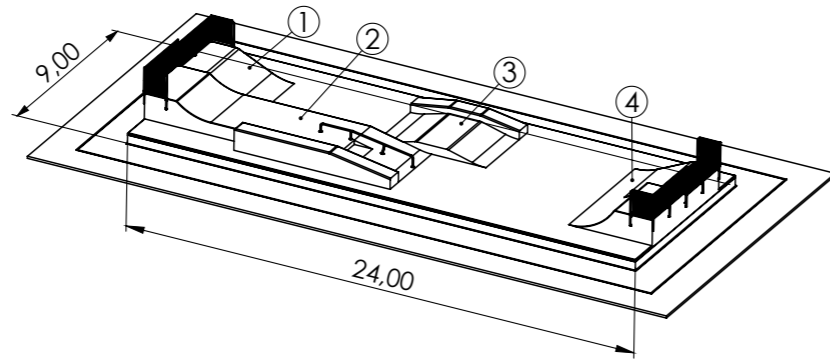

	Obstacle name	Height m	Width m	Length m	Barrier height from platform m
1	Bank	1,0	3,0	4,0	2,2
2	Doubleset	1,2	3,75	12,0	2,4
3	Funbox	0,4/0,7	3,75	5,2	
4	QP+Bank set	1,2/1,0	6,0	4,0	2,4/2,2

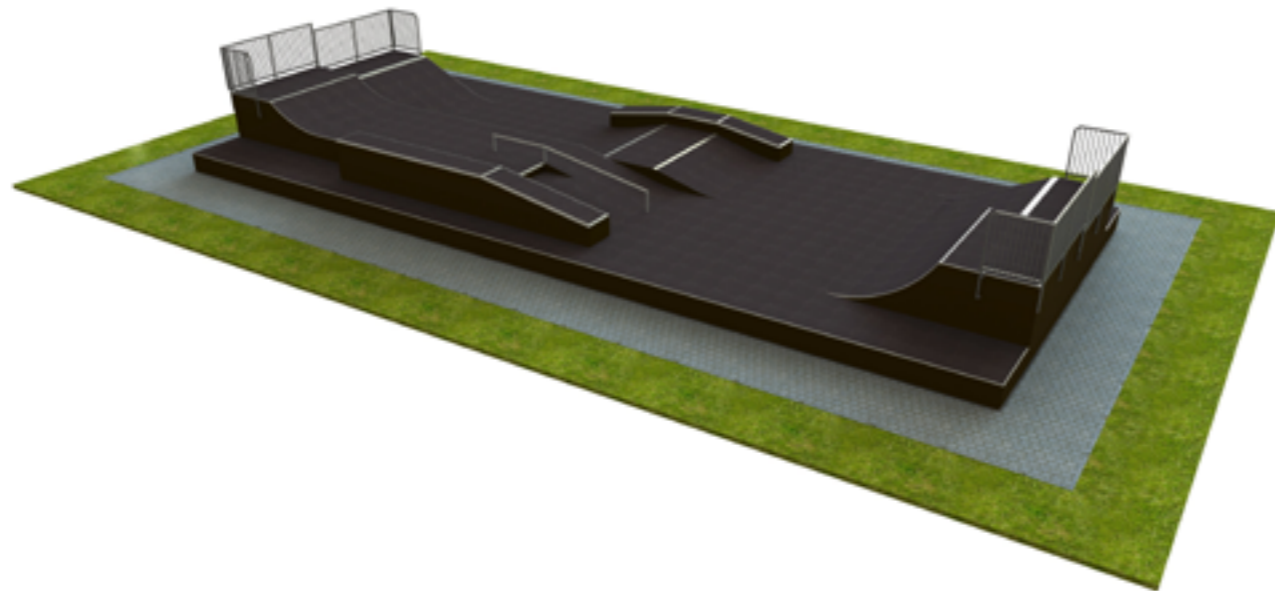

M505



Riding surface: 239m²
 Dimensions: 21x10,5x1,5m
 Platform height: 0,2m

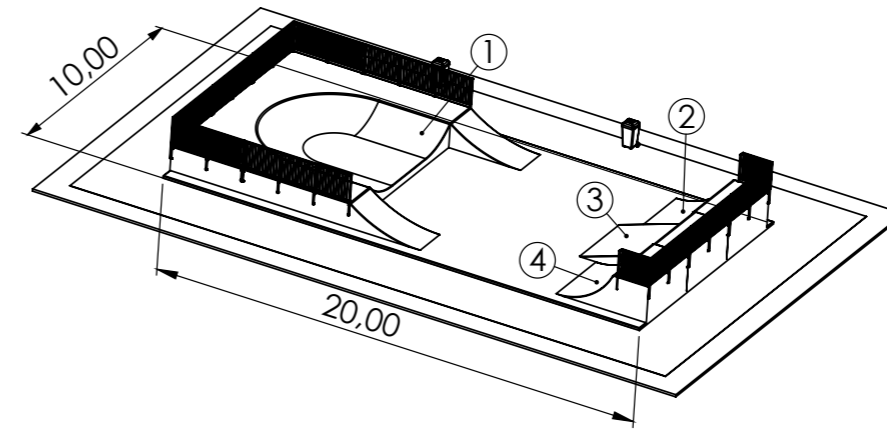

	Obstacle name	Height m	Width m	Length m	Barrier height from platform m
1	Bowl set	1,0	9,0	10,5	2,2
2	Quarterpipe	1,5	3,0	3,8	2,7
3	Bank with drop	1,5	3,0	4,5	2,7
4	Quarterpipe	1,5	3,0	3,8	2,7

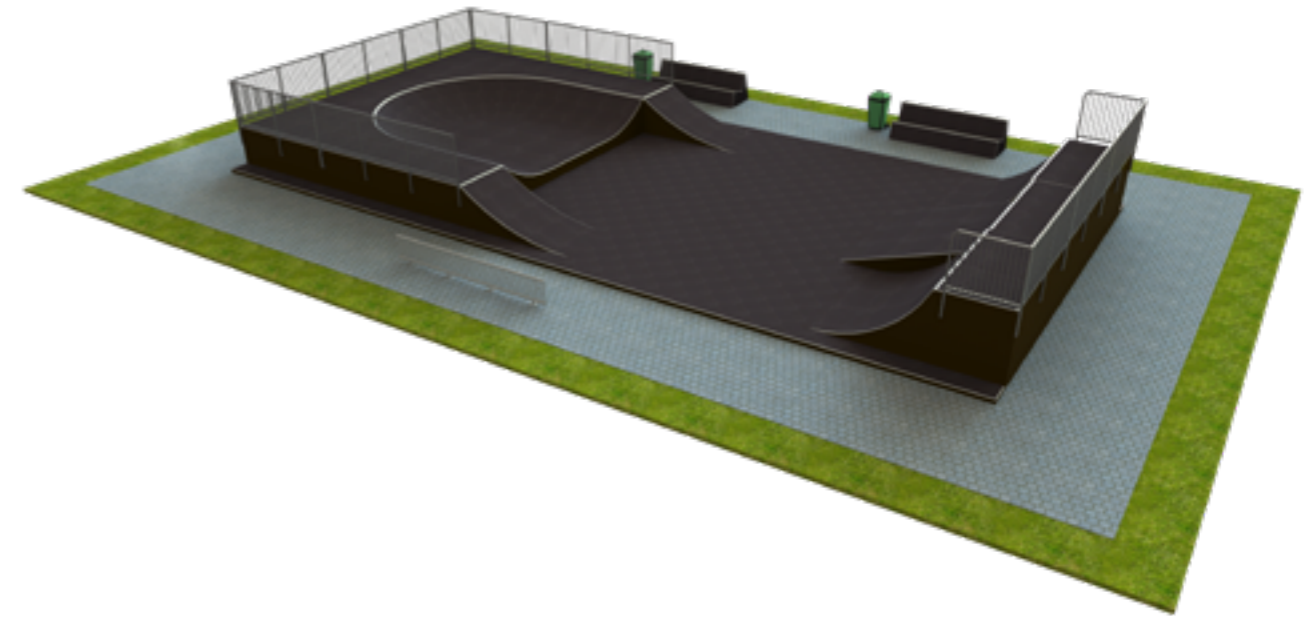

M510



Riding surface: 230m²
 Dimensions: 21x9x1,5m
 Platform height: 0,5m

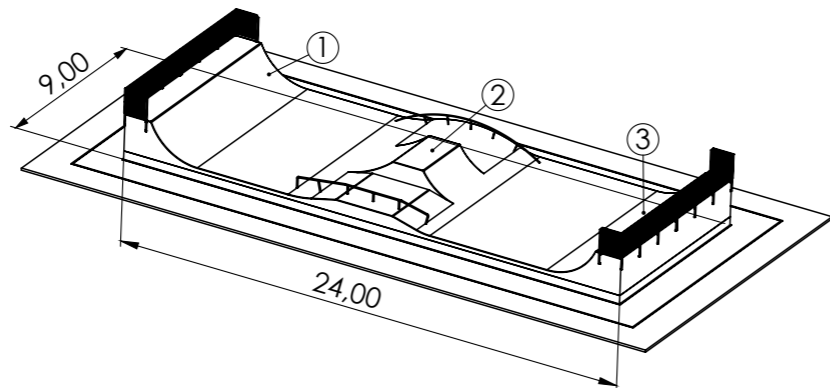

	Obstacle name	Height m	Width m	Length m	Barrier height from platform m
1	Quarterpipe	1,5	9,0	3,6	2,7
2	Flybox set	1,2/0,4	9,0	7,0	
3	Quarterpipe	1,5	9,0	3,6	2,7

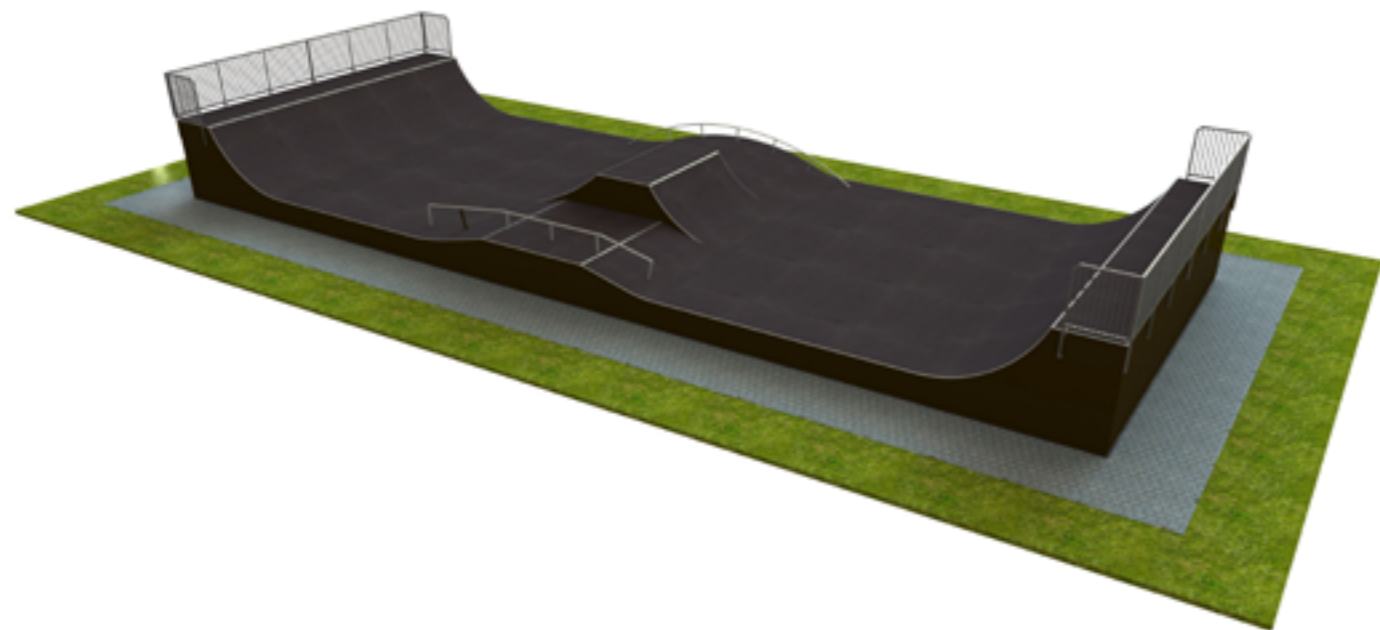

M515



Riding surface: 304m²
 Dimensions: 30x10,5x2,5m
 Platform height: 0,25/0,65m

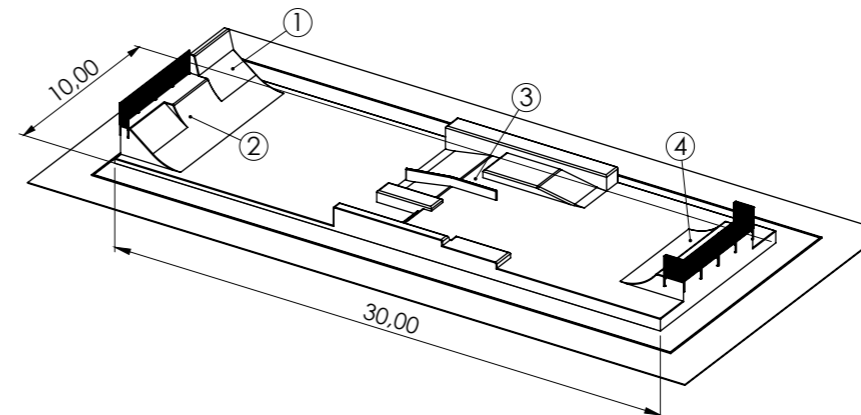

	Obstacle name	Height m	Width m	Length m	Barrier height from platform m
1	Wallride	2,5	3,0	3,3	
2	QP set	1,5	6,0	3,3	2,7
3	Funbox set	0,8/0,4	10,0	8,9	
4	Quarterpipe	1,0	6,0	3,5	2,2

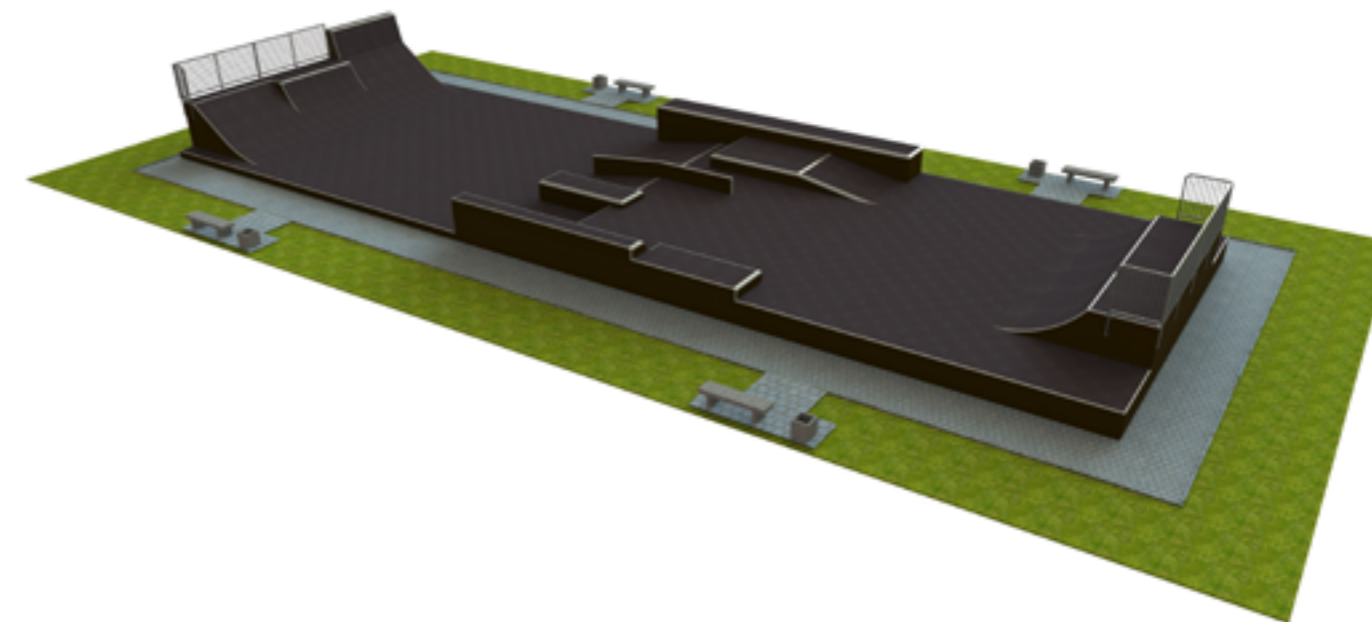

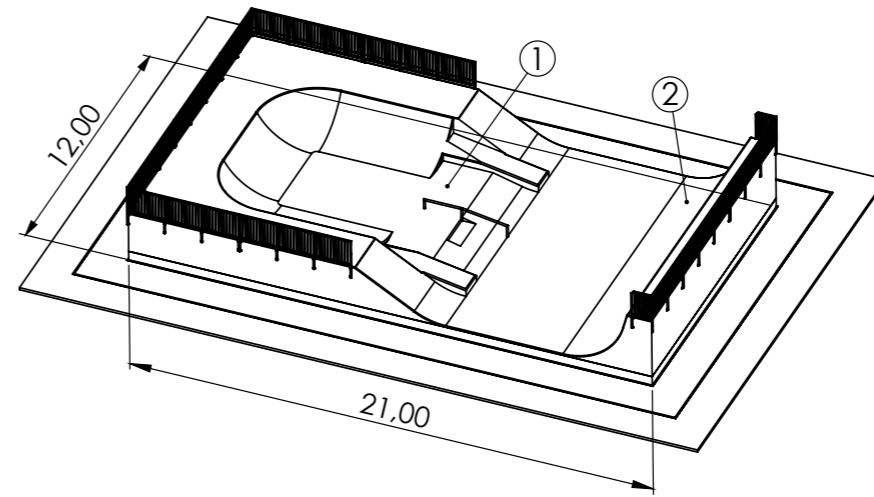

M525

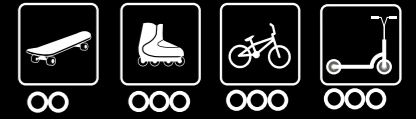

Riding surface: 290m²
 Dimensions: 21x12x2,5m
 Platform height: 0,45m

	Obstacle name	Height m	Width m	Length m	Barrier height from platform m
1	Bowl set	1,7	12,0	12,7	2,9
2	Quarterpipe	2,5	12,0	3,6	3,7

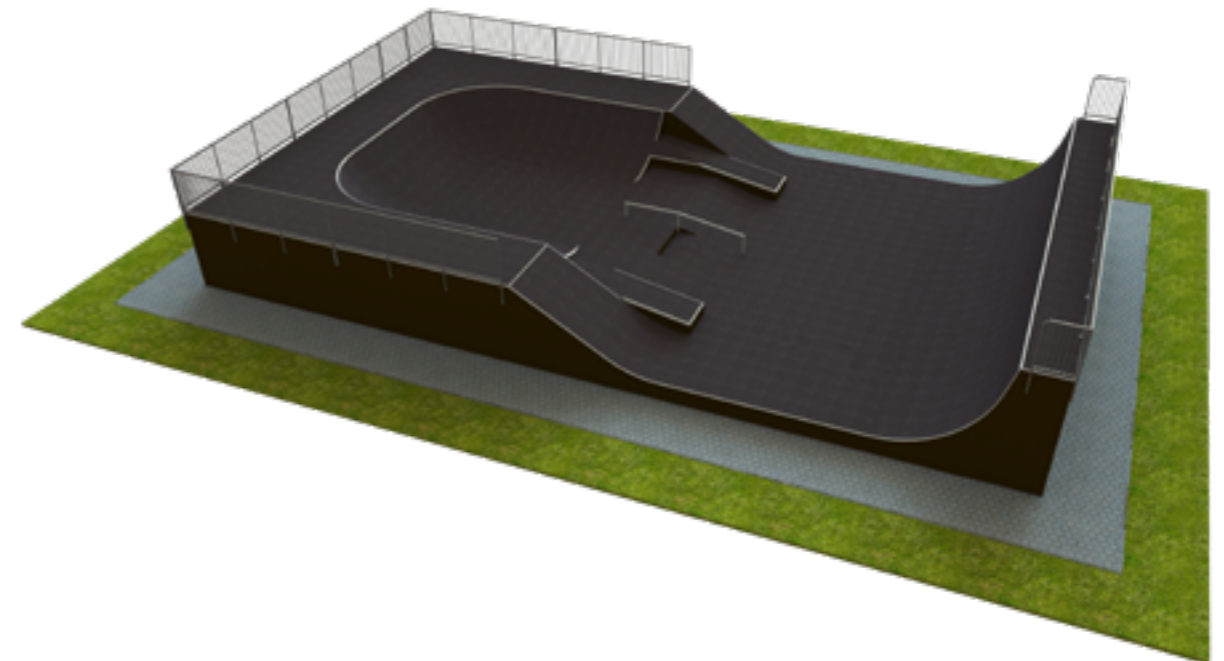

M530



Riding surface: 350m²
 Dimensions: 24x12x4m
 Platform height: 0,55m

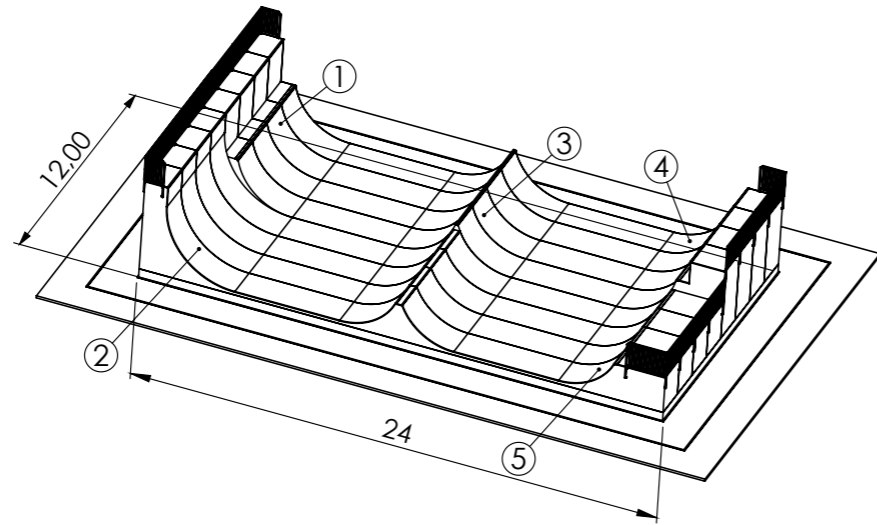

	Obstacle name	Height m	Width m	Length m	Barrier height from platform m
1	Quarterpipe with drop	4,0	6,0	4,1	5,2
2	Quarterpipe	4,0	6,0	4,1	5,2
3	Spine set	1,5/1,8	12,0	5,0	
4	Quarterpipe with drop	3,0	6,0	4,5	4,2
5	Quarterpipe	1,5	6,0	4,5	2,7

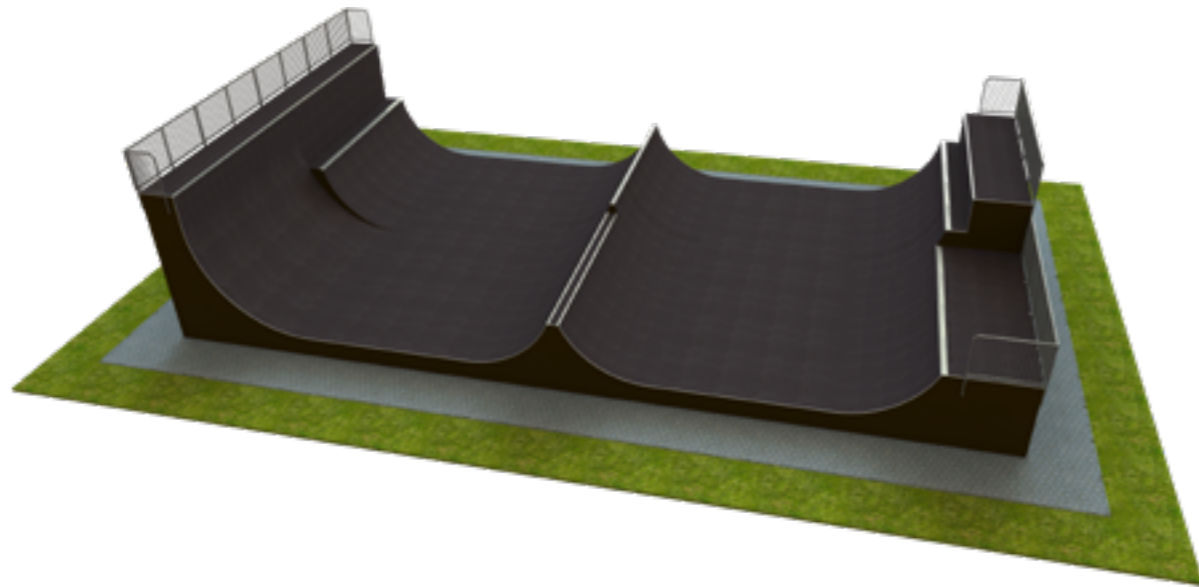

M535



Riding surface: 538m²
 Dimensions: 30x30x9x2m
 Platform height: 0,3/0,7m

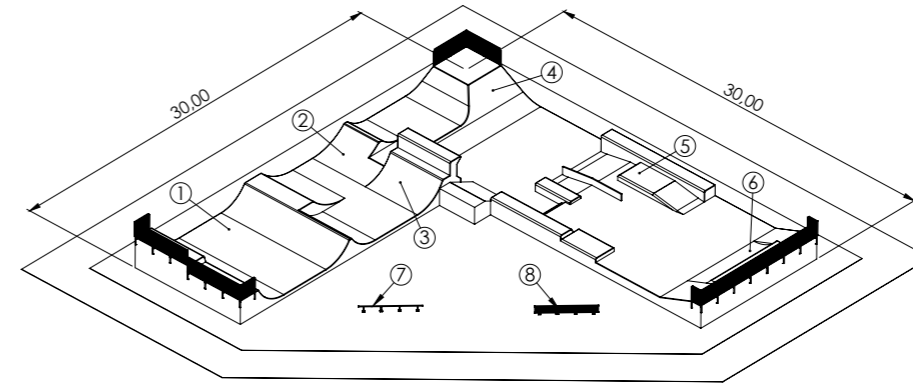

	Obstacle name	Height m	Width m	Length m	Barrier height from platform m
1	Miniramp	2,0/1,5/1,2	9,0	14,3	2,7/3,2
2	Spine	1,2	3,0	5,0	
3	Quarterpipe with drop	2,5	4,5	4,0	
4	Pyramid corner	1,5	6,4	6,4	2,7
5	Funbox set	0,4/0,8	10,5	8,9	
6	QP+Bank set	1,0	10,5	3,5	2,2
7	Grind rail	0,4	0,06	4,0	
8	Grind rail	0,6	0,06	4,0	

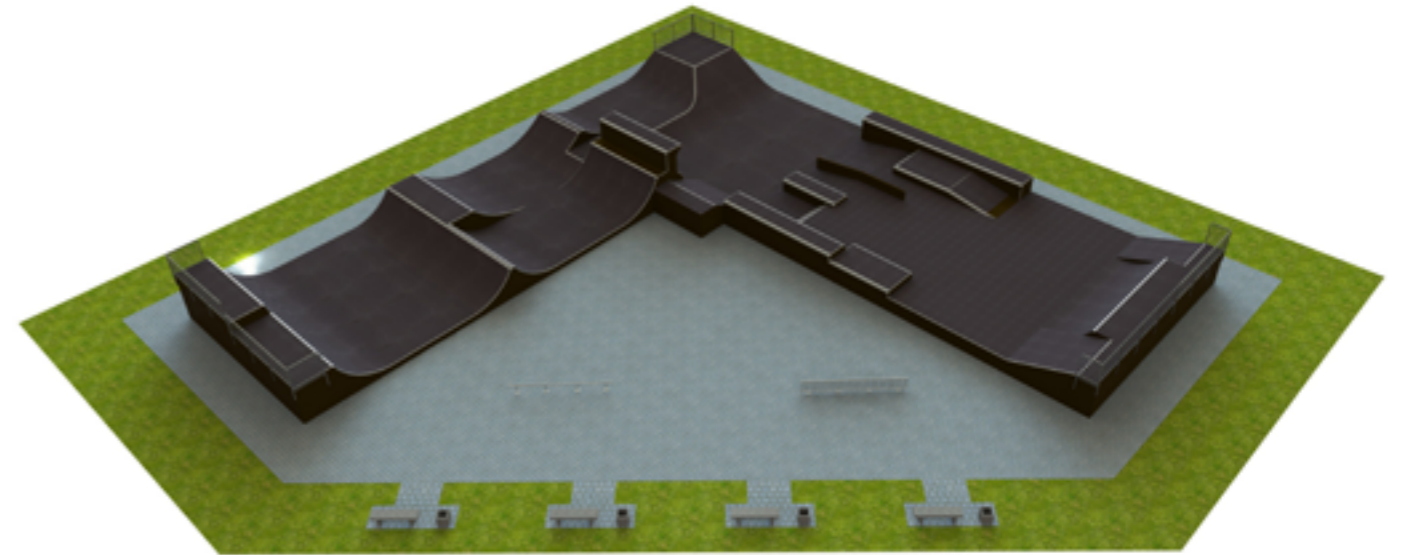

M540



Riding surface: 572m²
 Dimensions: 27x21x3m
 Platform height: 0,3/0,7m

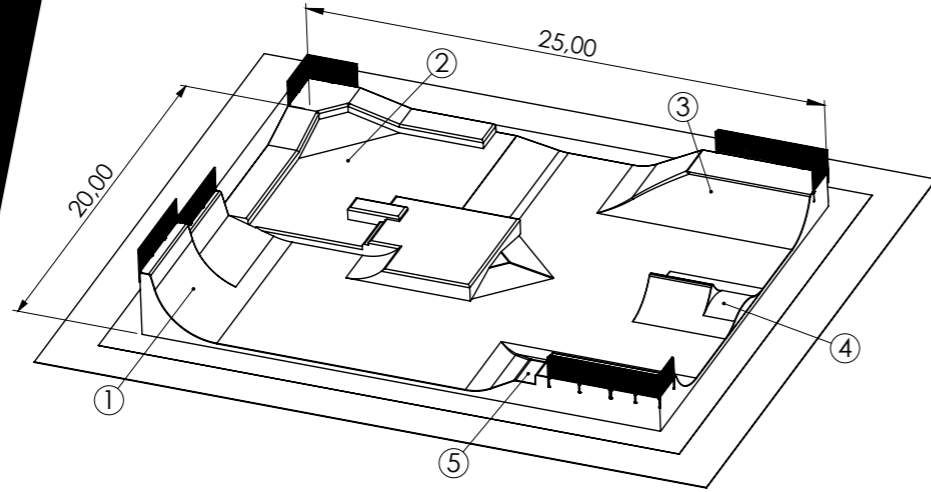

	Obstacle name	Height m	Width m	Length m	Barrier height from platform m
1	Quarterpipe set	3,0/2,0	9,0	3,6	3,2/4,2
2	Funbox set	0,4/0,8/1,4	13,0	15,8	2,6
3	Quarterpipe corner	1,5	9,5	4,3	2,7
4	Spine	1,2	4,5	4,5	
5	Quarterpipe corner	1,5/1,0	9,5	4,3	2,7

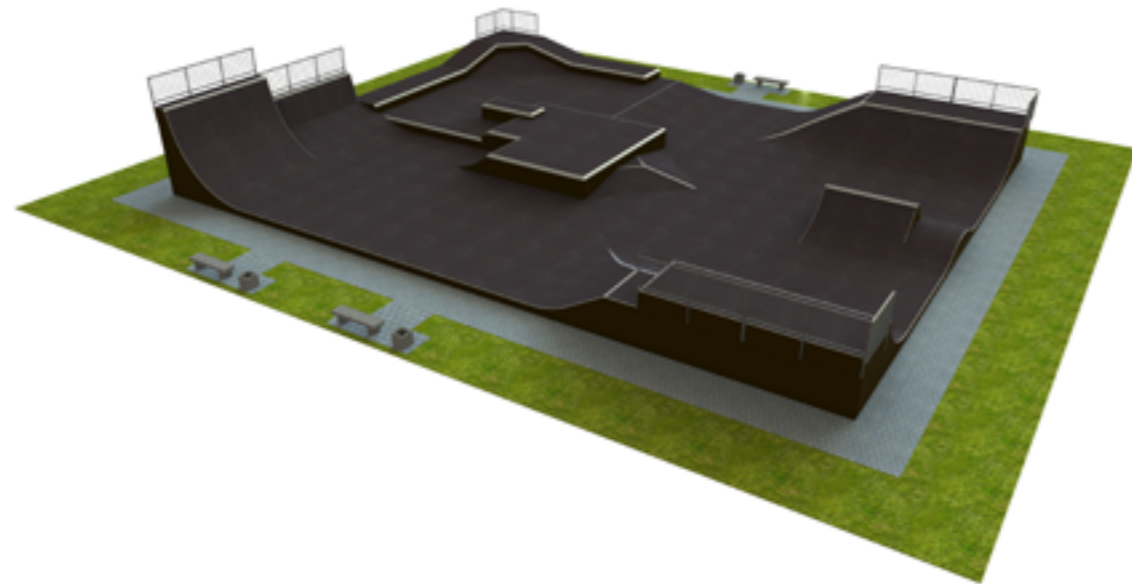

70

M545



Riding surface: 584m²
 Dimensions: 30x18x3m
 Platform height: 0,5m

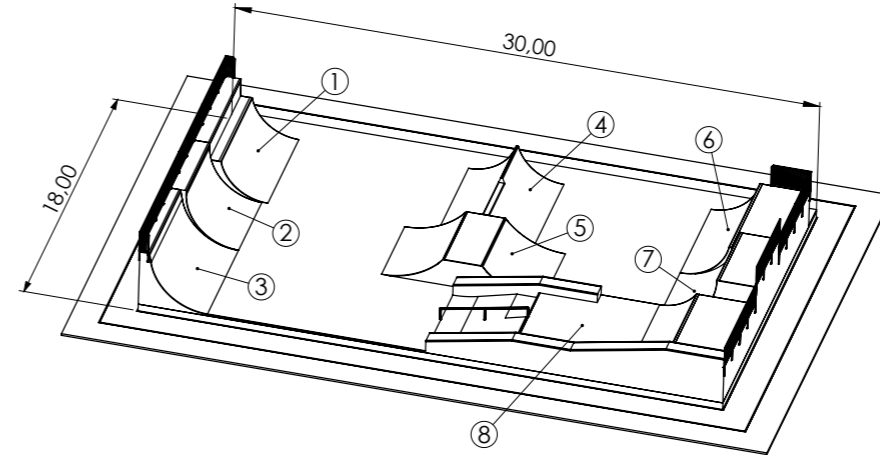

	Obstacle name	Height m	Width m	Length m	Barrier height from platform m
1	Quarterpipe with drop	3,0	6,0	3,9	4,2
2	Quarterpipe	3,0	4,5	3,6	4,2
3	Quarterpipe	3,0	4,5	3,6	4,2
4	Spine	1,5/1,8	6,0	4,9	
5	Flybox	1,5	4,5	8,3	
6	Quarterpipe	2,0	6,0	5,0	3,2
7	Quarterpipe	3,0	4,5	5,0	4,2
8	Doubleset	2,0/1,5/1,0	6,0	15,3	3,2

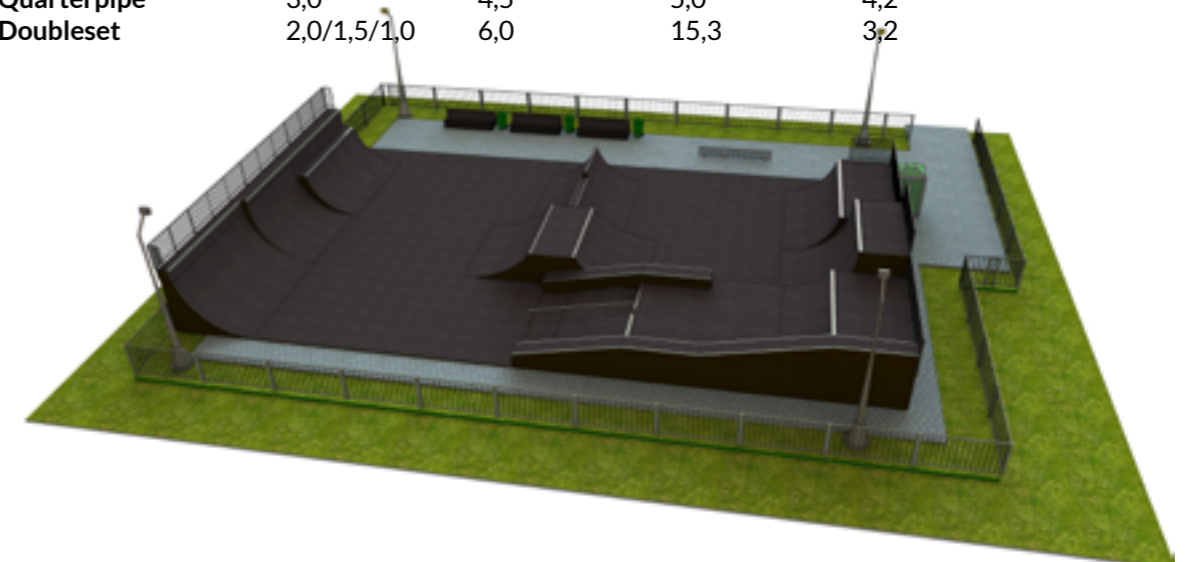

71

M550



Riding surface: 557m²
 Dimensions: 24x21x3m
 Platform height: 0,3/0,7m

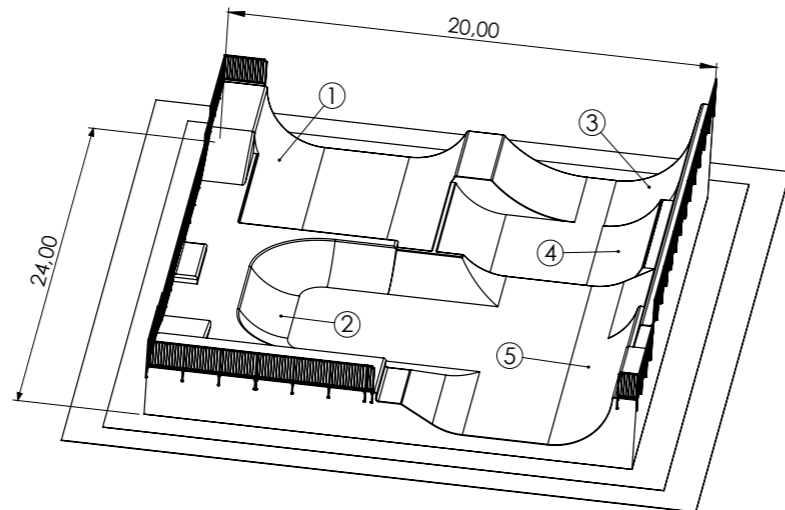

	Obstacle name	Height m	Width m	Length m	Barrier height from platform m
1	Miniramp	2,5/1,5	10,0	15,0	3,7
2	Bowl	1,5/1,1	14,0	13,0	2,7
3	Wallride	4,0	4,0	3,8	5,2
4	Quarterpipe with drop	4,0	6,0	3,8	5,2
5	Quarterpipe set	2,5/3,6	14,0	3,5	4,8/3,7

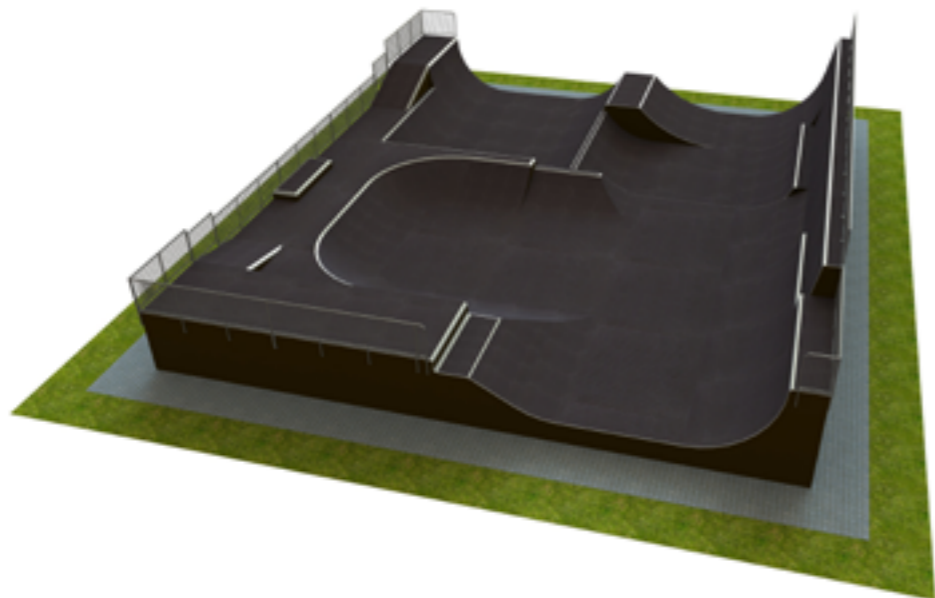

72

M555



Riding surface: 933m²
 Dimensions: 33x30x2m
 Platform height: 0,3/0,8m

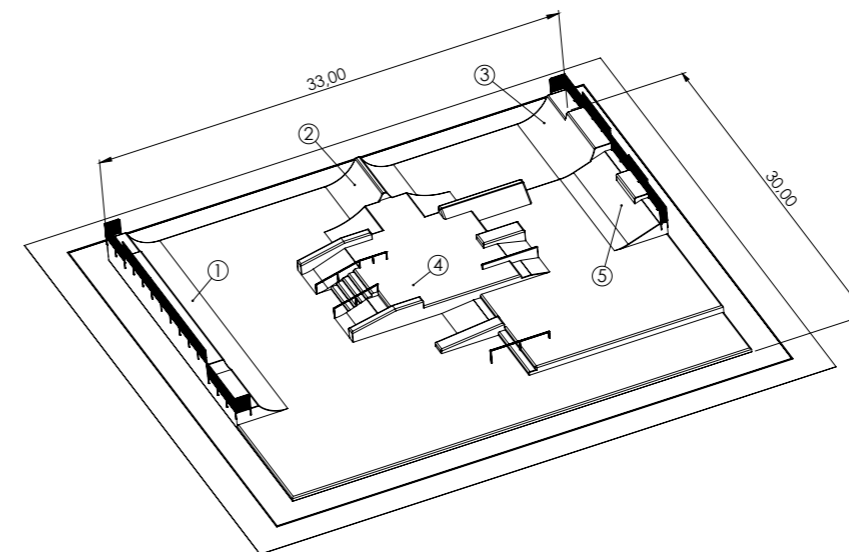

	Obstacle name	Height m	Width m	Length m	Barrier height from platform m
1	Quarterpipe set	2,0/1,0	21,0	3,7	3,2/2,2
2	Spine	1,5	4,5	4,9	
3	Quarterpipe set	1,5/2,0	7,5	7,0	2,7/3,2
4	Funbox set	1,0/1,5	21,0	22,7	
5	Bank with drop	1,0/1,3	9,0	3,9	2,2/2,5

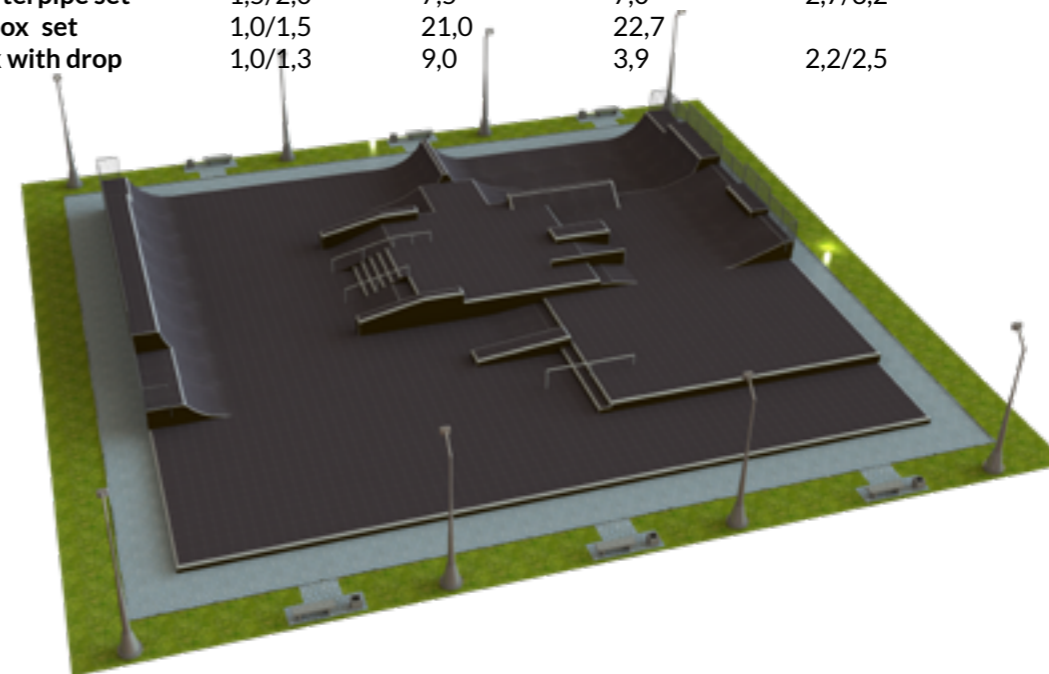

73

Seperate skatepark elements

Separate skatepark elements are a good option for designing a suitable skatepark according to your requirements or for adding additional skate elements to an existing park. The construction of elements allows them to be placed on any flat surface such as concrete or asphalt. Structures are available in 4 different material versions: BASE, BASE+, STEEL and STEEL PRO.



Miniramps

Halfpipes or also called Miniramps have a unique monolithic structure. They can be installed anywhere, even to surfaces without asphalt. The riding surface has no transitions to asphalt and is therefore smoother and allows to gain faster speed while riding as well as greater safety and means fewer injuries in the event of a fall. The curved surface of halfpipe directs riders up and above the ramp, enabling riders to perform a trick and then land back onto the ramp and roll away. They are also used as elements for different types of manoeuvres.

Structures are available in 4 different material versions: BASE, BASE+, STEEL and STEEL PRO.

MINIRAMP



Technical information and variations

Product	Code	Lenght	Width	Height
Miniramp	MR01A	9,0	3,6	1,2
Miniramp	MR01B	9,4	3,6	1,5
Miniramp	MR01C	9,4	4,8	1,5
Miniramp	MR01D	9,9	4,8	1,7
Miniramp	MR01E	9,9	6,0	1,7
Miniramp	MR01F	11,2	6,0	2,0
Miniramp	MR01G	11,2	9,0	2,0

DOUBLE MINIRAMP



Technical information and variations

Product	Code	Lenght	Width	Height
Double MR	MR02A	17,6	3,6	1,5
Double MR	MR02B	18,8	4,8	1,7
Double MR	MR02C	19,0	6,0	2,0
Double MR	MR02D	20,0	9,0	2,0

COMBO MINIRAMP

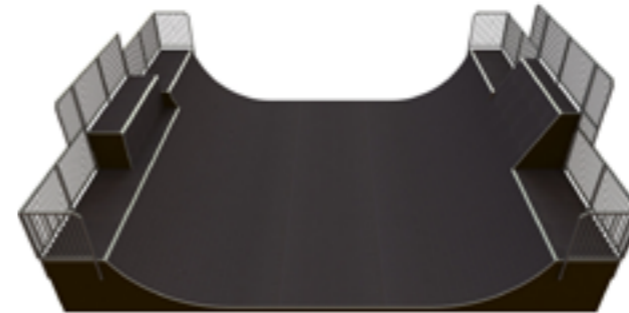

Technical information

Product	Code	Lenght	Width	Height
Combo Miniramp	MR03	12,0	9,0	3,0

VERT RAMP

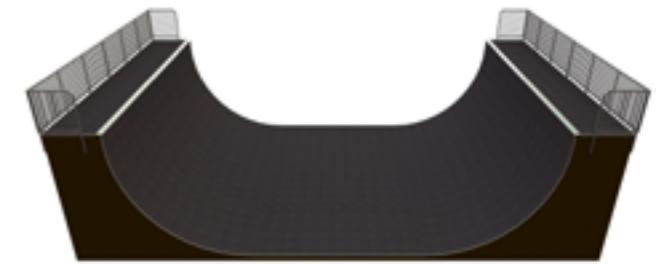

Technical information

Product	Code	Lenght	Width	Height
Vert Ramp	MR04	15,0	9,0	4,0

Quarterpipes

Quarterpipes are used to gain speed for middle obstacles of the skate park like funboxes, grind boxes, rails, etc. The curved surface of a quarterpipe directs riders up and above the ramp, enabling riders to perform a trick and then land back onto the ramp and roll away. They are also used as elements for different types of manoeuvres. Quarterpipes can be connected with other quarterpipes of different heights or with Banks, Roll-ins and Wallrides to create a wall. Structures are available in 4 different material versions: BASE, BASE+, STEEL and STEEL PRO.

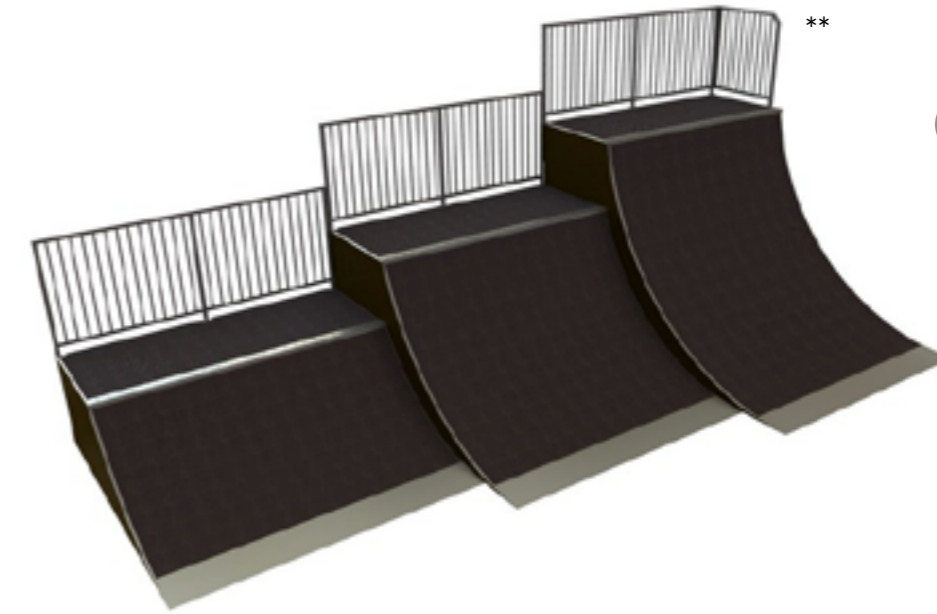
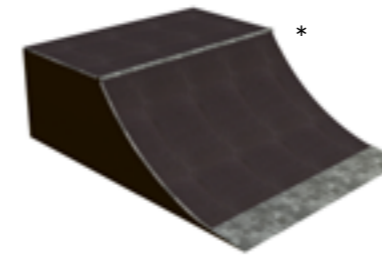

Technical information and variations

Product	Code	Lenght	Width	Height
Quarterpipe	QP60A	2,6	1,22	0,6
Quarterpipe	QP60B	2,6	2,44	0,6
Quarterpipe	QP80A	2,6	1,22	0,8
Quarterpipe	QP80B	2,6	2,44	0,8
Quarterpipe	QP100A	3	1,22	1
Quarterpipe	QP100B	3	2,44	1
Quarterpipe	QP120A	3,4	2,44	1,2
Quarterpipe	QP120B	3,4	3,66	1,2
Quarterpipe	QP150A	3,45	2,44	1,5
Quarterpipe	QP150B	3,45	3,66	1,5
Quarterpipe	QP170A	3,5	2,44	1,7
Quarterpipe	QP170B	3,5	3,66	1,7
Quarterpipe	QP200A	3,6	2,44	2
Quarterpipe	QP200B	3,6	3,66	2
Quarterpipe	QP220A	4	2,44	2,2
Quarterpipe	QP220B	4	3,66	2,2

*Quarterpipes prices and measurements don't include safety railing. Safety railing is mandatory for elements higher than 1m. Safety railing product code SKATEP2

** Picture is illustrative. There are three different quarterpipes with three different heights.

Quarterpipe with subbox

Quarterpipes with subbox are used to gain speed for middle obstacles of the skate park like funboxes, grind boxes, rails, etc. The curved surface of a quarter pipe directs riders up and above the ramp, enabling riders to perform a trick and then land back onto the ramp and roll away. They also are used as elements for different types of manoeuvres. Quarterpipes can be connected with other quarterpipes of different heights or with Banks, Roll-ins and Wallrides to create a wall. Structures are available in 4 different material versions: BASE, BASE+, STEEL and STEEL PRO.



Technical information and variations

Product	Code	Length	Width	Height	
Quarterpipe with subbox	QpSB150A	3,45	2,44	1,9	
Quarterpipe with subbox	QpSB150B	3,45	3,66	1,9	
Quarterpipe with subbox	QpSB170A	3,55	2,44	2,1	
Quarterpipe with subbox	QpSB170B	3,55	3,66	2,1	
Quarterpipe with subbox	QpSB200A	3,6	2,44	2,4	
Quarterpipe with subbox	QpSB200B	3,6	3,66	2,4	

*Quarterpipes with subbox prices and measurements don't include safety railing. Safety railing is mandatory for elements higher than 1m. Safety railing product code SKATEP2

Banks and flat banks

Banks are used to gain speed for middle obstacles of the skate park like funboxes, grind boxes, rails, etc. There are two types of banks – with or without radius. Typically, banks are placed at the perimeter of a skatepark for riders to gain speed for middle elements of different types, to drop in or perform technical tricks and manoeuvres. Banks can be connected with other banks of different heights or with Quarterpipes, Roll-ins and Wallrides to create a wall. Structures are available in 4 different material versions: BASE, BASE+, STEEL and STEEL PRO.

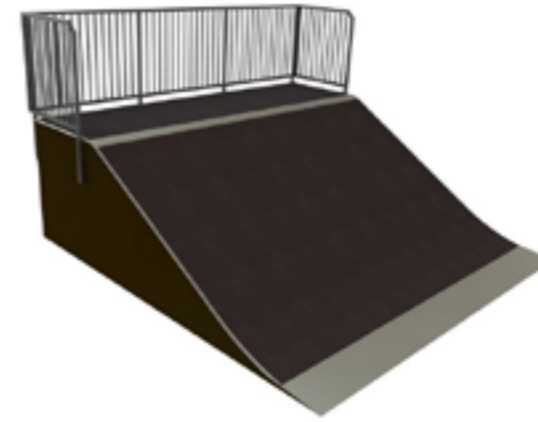

Technical information and variations

Product	Code	Lenght	Width	Height
Bank	BN60A	3	1,22	0,6
Bank	BN60B	3	2,44	0,6
Bank	BN80A	3	1,22	0,8
Bank	BN80B	3	2,44	0,8
Bank	BN100A	3,9	1,22	1
Bank	BN100B	3,9	2,44	1
Bank	BN120A	4,3	2,44	1,2
Bank	BN120B	4,3	3,66	1,2
Bank	BN150A	4,4	2,44	1,5
Bank	BN150B	4,4	3,66	1,5
Bank	BN170A	4,8	2,44	1,7
Bank	BN170B	4,8	3,66	1,7
Bank	BN200A	5,3	2,44	2
Bank	BN200B	5,3	3,66	2
Bank	BN220A	5,6	2,44	2,2
Bank	BN220B	5,6	3,66	2,2

Technical information and variations

Product	Code	Lenght	Width	Height
Flat bank	BN60FA	2,6	1,22	0,6
Flat bank	BN60FB	2,6	2,44	0,6
Flat bank	BN100FA	3,5	1,22	1
Flat bank	BN100FB	3,5	2,44	1
Flat bank	BN120FA	4	2,44	1,2
Flat bank	BN120FB	4	3,66	1,2

*Bank and flat bank prices and measurements don't include safety railing. Safety railing is mandatory for elements higher than 1m. Safety railing product code SKATEP2

Vertical Wallride

Vertical Wallride is a more challenging high element of the quarterpipes family, usually placed next to a standard Quarterpipe or Bank, slightly behind. Structures are available in 4 different material versions: BASE, BASE+, STEEL and STEEL PRO.

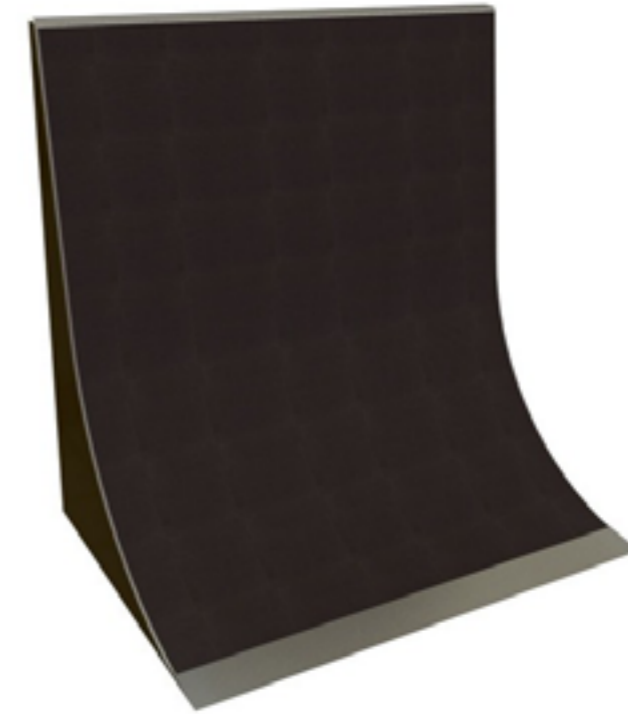

Technical information and variations

Product	Code	Lenght	Width	Height
Vertical wallride	WL01A	3,5	3,6	2,5
Vertical wallride	WL01B	3,9	4,8	3,5
Vertical wallride	WL01B	3,9	4,8	4,5

Spines

Spines are used for fun and learning of new tricks. Spines can be free-standing or used in combination with Funboxes, Banks or other platforms. Structures are available in 4 different material versions: BASE, BASE+, STEEL and STEEL PRO.

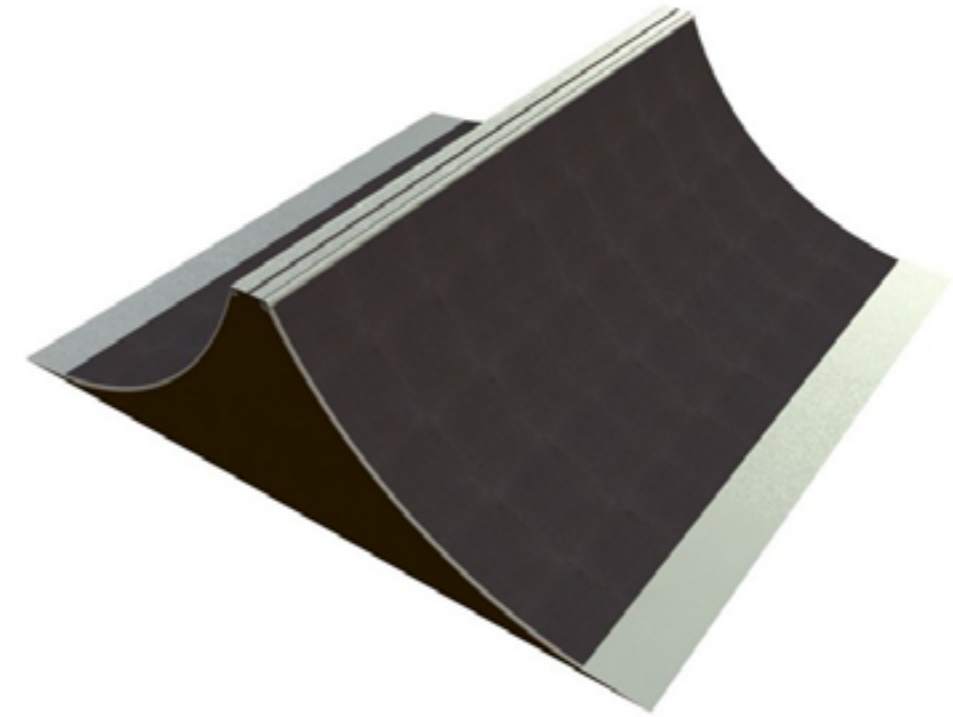

Technical information and variations

Product	Code	Length	Width	Height
Spine	SPN60A	3	1,22	0,6
Spine	SPN60B	3	2,44	0,6
Spine	SPN100A	3,8	2,44	1
Spine	SPN100B	3,8	3,66	1
Spine	SPN120A	4	2,44	1,2
Spine	SPN120B	4	3,66	1,2
Spine	SPN150A	4,7	2,44	1,5
Spine	SPN150B	4,7	3,66	1,5

Flyboxes

Flyboxes are used for fun and learning of new tricks. They are best for beginners to learn new tricks, easy to slide on and off. They can be free-standing or used in combination with Funboxes or other skatepark elements. Usually, they are positioned in the middle of the skating park. Structures are available in 4 different material versions: BASE, BASE+, STEEL and STEEL PRO.

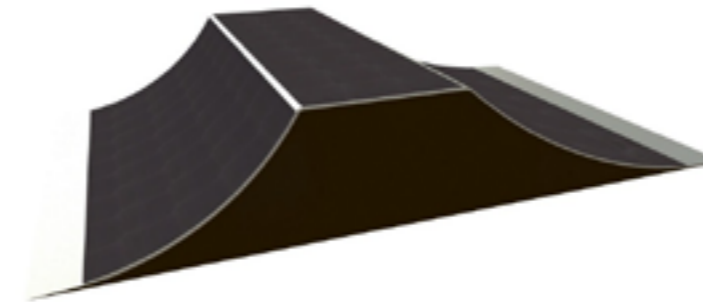

Flybox JBX01 shape

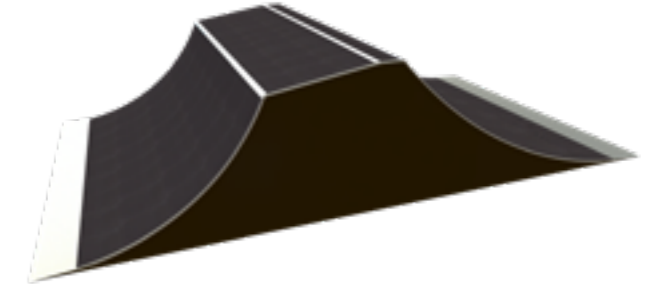

Flybox JBX02 shape

Technical information and variations

Product	Code	Lenght	Width	Height
Flybox	JBX01A	6	1,22	0,8
Flybox	JBX01B	6	2,44	0,8
Flybox	JBX01C	6,5	2,44	1
Flybox	JBX01D	6,5	3,66	1
Flybox	JBX01E	6,8	2,44	1,2
Flybox	JBX01F	6,8	3,66	1,2
Flybox	JBX01G	7,3	2,44	1,5
Flybox	JBX01H	7,3	3,66	1,5

Technical information and variations

Product	Code	Lenght	Width	Height
Flybox	JBX02A	7,2	2,44	1,5
Flybox	JBX02B	7,2	3,66	1,5
Flybox	JBX02C	9	3,66	2
Flybox	JBX02D	9	4,88	2

Grind box

Grind box is a rectangle box used for skateboarding. Grind box has a metal edge used for grinding and performing tricks. This item is another general ramp used in any skateboard park. Structures are available in 4 different material versions: BASE, BASE+, STEEL and STEEL PRO.

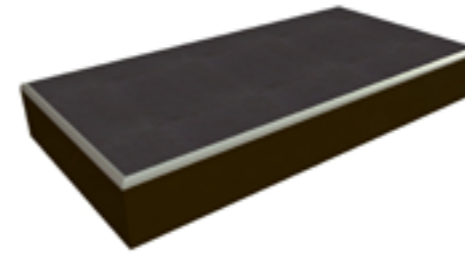

Grind box MBX01
L 2,8 x W 1,22 x H 0,4

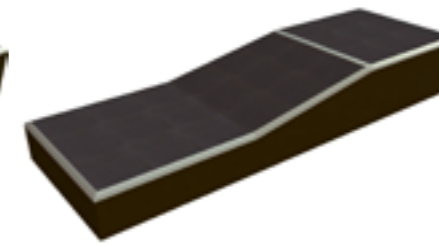

Grind box MBX02
L 4,8 x W 1,22 x H 0,4-0,6

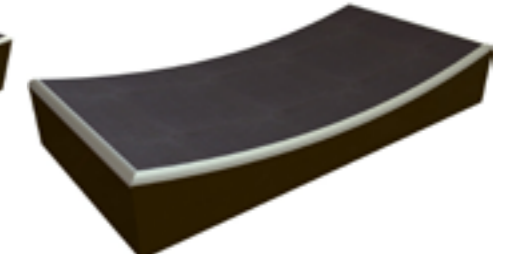

Grind box MBX03
L 2,8 x W 1,22 x H 0,5

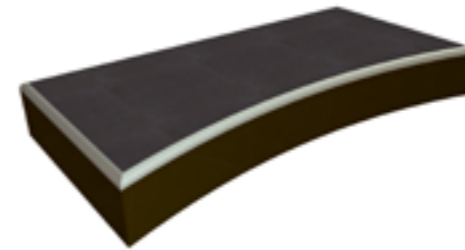

Grind box MBX04
L 2,8 x W 1,22 x H 0,35

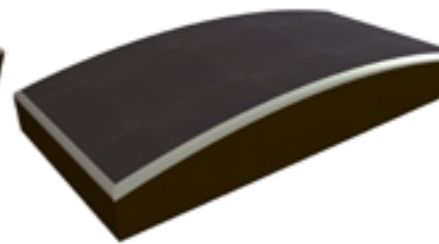

Grind box MBX05
L 2,8 x W 1,22 x H 0,3

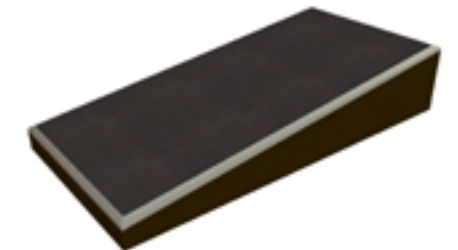

Grind box MBX06
L 2,8 x W 1,22 x H 0,6

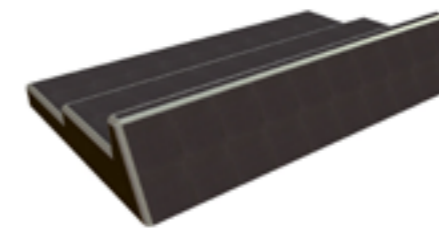

Grind box MBX07
L 2,8 x W 3 x H 0,9

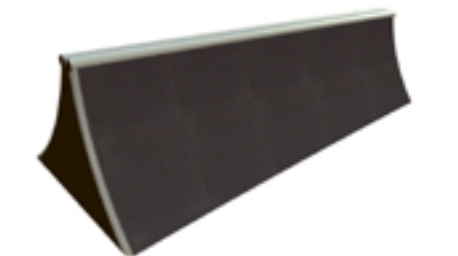

Grind box MBX08
L 2,8 x W 0,9 x H 0,9

Funboxes

Funboxes are combination of different ramps with platforms, rails and corners. They are used for fun and for performing a wide range of tricks. Usually, they are positioned in the middle of the skatepark and are used as a common element of a typical skatepark. Structures are available in 4 different material versions: BASE, BASE+, STEEL and STEEL PRO.

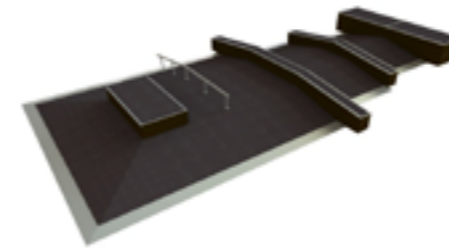

Funbox SFB01
L 14,3xW 8,0xH 1,0

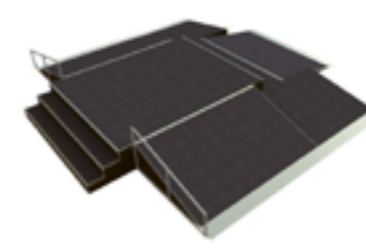

Funbox SFB02
L 10,7xW 9,4xH 0,9/1,5

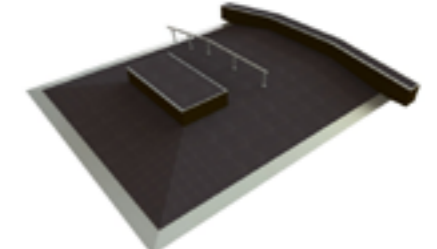

Funbox SFB03
L 7,8xW 7,4xH 1,0

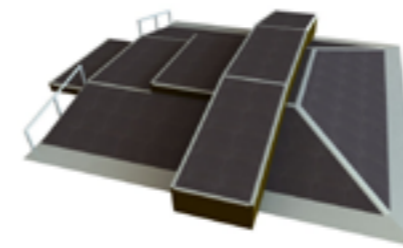

Funbox SFB04
L 7,2xW 6,8xH 1,0

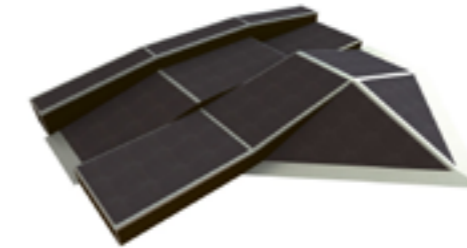

Funbox SFB05
L 6,9xW 5,6xH 0,8

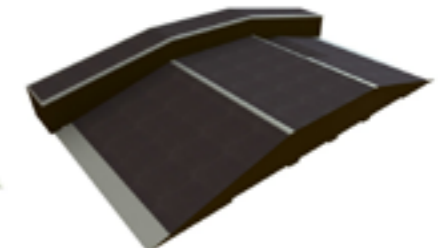

Funbox SFB06
L 6,6xW 3,75xH 1,0

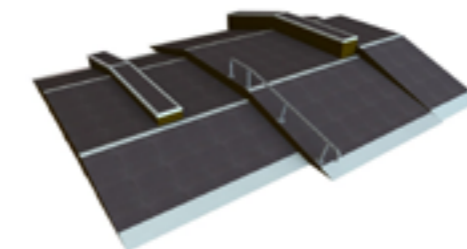

Funbox SFB07
L 7xW 7,5xH 1,0

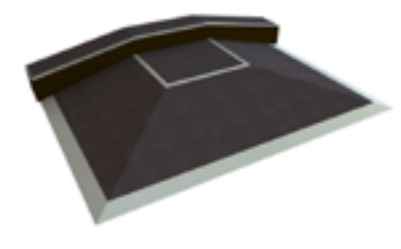

Funbox SFB08
L 6,6xW 4,4xH 1,0

Kickers

Kicker ramps are smaller items designed for street courses and skate parks. They can be used free-standing or together with another skatepark element. Kicker ramps are used for a skateboard, scooter, or BMX to launch into the air or perform tricks. Structures are available in 4 different material versions: BASE, BASE+, STEEL and STEEL PRO.

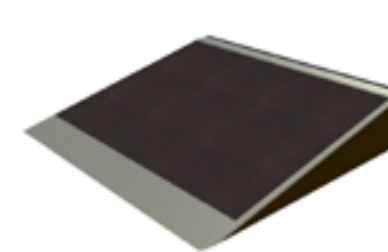

Kicker KICK01A
L 1,2 x W 1,22 x H 0,3

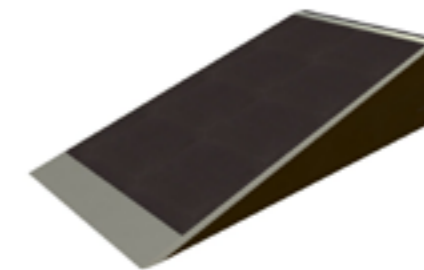

Kicker KICK01B
L 1,9 x W 1,22 x H 0,5

Grind rails

Grind rails (round or profile) provide challenges for experienced and novice skateboarders. Riders can finesse their balancing skills while grinding their way to the end. The rails are also used for jumping over. Rails could be free-standing or are used as diversity of Funboxes, Banks or other skate platforms.



Grind rail RAIL 01
Grind rail (straight, round)
L 5,0 x W 0,06 x H 0,4



Grind rail RAIL 02
Grind rail (2 heights, round)
L 5,5 x W 0,06 x H 0,4-0,6



Grind rail RAIL 03
Grind rail (straight, square shape)
L 4,0 x W 0,06 x H 0,4



Grind rail RAIL 04
Grind rail (round, curved shape)
L 4,0 x W 0,06 x H 0,4

Pyramid corner

Pyramid corner can be used as an alone standing element or as a larger element by installing together 2 or 4 pyramid corners. Four pyramid corners create a full pyramid with a platform on top that can be used for flat landing or flip tricks. Pyramid corners can be combined with some other skatepark elements as well. Structures are available in 4 different material versions: BASE, BASE+, STEEL and STEEL PRO.

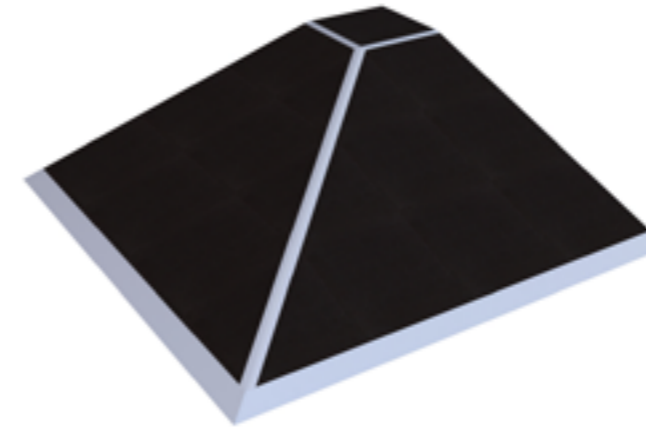

Pyramid corner

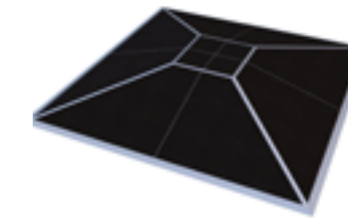

Pyramid full

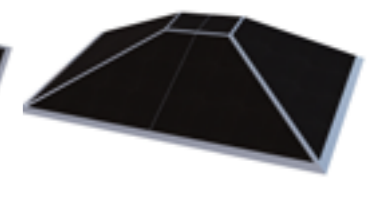

Pyramid half

Full pyramid can be made by placing 4 pyramid corners together.
Half pyramid can be made by placing 2 pyramid corners together.

Technical information and variations

Product	Code	Lenght	Width	Height
Pyramid corner	PIR01	1	1	0,3
Pyramid corner	PIR02	1,4	1,4	0,4
Pyramid corner	PIR03	2,1	2,1	0,6
Pyramid corner	PIR04	2,9	2,9	0,7
Pyramid corner	PIR05	3,22	3,22	0,9

Scoot pump

This ramp can be used for a skateboard, scooter, or BMX where you can do combo tricks that require rotations or choose just to roll over. This ramp has a rising and falling pattern. The scoot pump starts at the ground level, forms a pick, and goes down to the ground level. Skaters learn to control their speed while doing rotating tricks on the scoot pump. Structures are available in 4 different material versions: BASE, BASE+, STEEL and STEEL PRO.

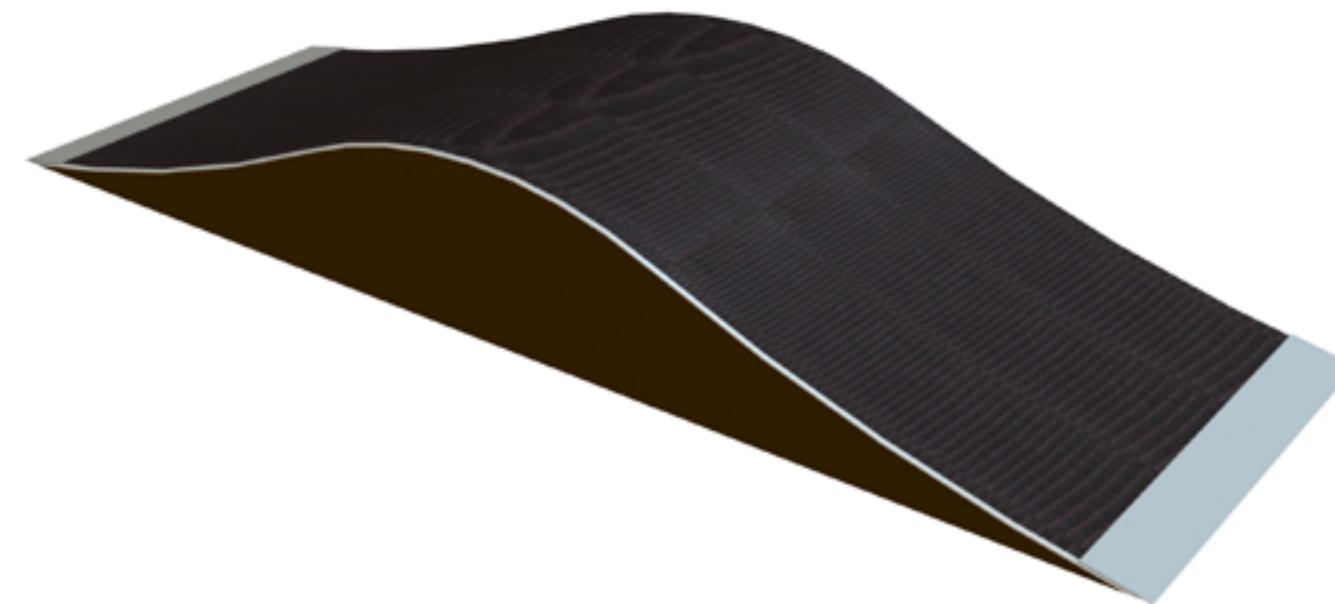

Technical information and variations

Product	Code	Length	Width	Height
Scoot pump	SQP01A	3,8	1,22	0,5
Scoot pump	SQP01B	3,8	2,44	0,5

Roll-in

Roll-in is a long sloping ramp used to gain speed for middle obstacles of the skate park like funboxes, grind boxes, rails, etc. Roll-ins are typically placed at the perimeter of a skatepark for riders to gain speed for middle elements of different types to perform technical tricks and manoeuvres. Roll-ins can be connected with Quarterpipes, Banks or Wallrides to create a wall. Structures are available in 4 different material versions: BASE, BASE+, STEEL and STEEL PRO.



Technical information and variations

Product	Code	Lenght	Width	Height
Roll-in	RLN100A	3,9	1,22	1
Roll-in	RLN100B	3,9	2,44	1
Roll-in	RLN120A	4,2	2,44	1,2
Roll-in	RLN120B	4,2	3,66	1,2
Roll-in	RLN150A	4,4	2,44	1,5
Roll-in	RLN150B	4,4	3,66	1,5
Roll-in	RLN170A	4,6	2,44	1,7
Roll-in	RLN170B	4,6	3,66	1,7
Roll-in	RLN200A	4,8	2,44	2
Roll-in	RLN200B	4,8	3,66	2
Roll-in	RLN220A	4,9	2,44	2,2
Roll-in	RLN220B	4,9	3,66	2,2
Roll-in	RLN300A	5,4	2,44	3,0
Roll-in	RLN300B	5,4	3,66	3,0

*Roll-in prices and measurements don't include safety railing. Safety railing is mandatory for elements higher than 1m. Safety railing product code SKATEP2



Tiptiptap

Skateparks

Tiptiptap OÜ
Veetorni tn. 9/1, Jüri alevik
Rae vald, 75301
Harjumaa, Estonia
Phone +372 657 6222
E-mail: info@tiptiptap.ee
www.tiptiptap.ee
www.facebook.com/tiptiptap